



City of Coquitlam

Contract Documents

74747

Quarry Road Enhancements



Table of Contents

Contract No. 74747

Quarry Road Enhancements

Project Construction Documents

Table of Contents

The complete **Project Construction Documents** consist of the following parts:

1. Standard Documents – supplied	Page
Table of Contents	TC 1 to TC 2
Invitation to Tender	IN 1 to IN 3
Instruction to Tenderers	
▪ Table of Contents.....	IT 1
▪ Instructions to Tenderers.....	IT 2 to IT 13
Form of Tender, including	
▪ Form of Tender Summary	FT 1
▪ Form of Tender	FT 2 to FT 5
▪ Appendix 1 – Schedule of Quantities and Unit Prices.....	FT 6 to FT 7
▪ Appendix 2 – Preliminary Construction Schedule	FT 8
▪ Appendix 3 – Experience of Superintendent.....	FT 9
▪ Appendix 4 – Comparable Work Experience.....	FT 10
▪ Appendix 5 – Subcontractors	FT 11
▪ Appendix 6 – Bid Bond.....	FT 12
▪ Appendix 7 – Certificate of Compliance for Contract Insurance	FT 13
Agreement between Owner and Contractor	AGT 1 to AGT 4
Schedule 1 – Schedule of Contract Documents.....	AGT 5
Schedule 2 – List of Drawings	AGT 6 to AGT 7
Supplementary General Conditions – Table of Contents.....	SGC 1 to SGC 2
▪ Supplementary General Conditions, including.....	SGC 3 to SGC 25
▪ Appendices:	
▪ Appendix I Performance Bond.....	SGC 19 to SGC 20
▪ Appendix II labour and Material Payment Bond	SGC 21 to SGC 23
▪ Appendix III Certificate of Insurance.....	SGC 24
▪ Appendix IV Prime Contractor Designation	SGC 25

Table of Contents

Supplementary Contract SpecificationsSS 1 to SS 66

Appendix A – Traffic Management Detail SpecificationsTMP 1 to TMP 8

Appendix B – Archaeological Chance Find Procedures.....ACF 1 to ACF 19

Appendix C – Additional InformationAI 1 to AI 2

Appendix D – Construction Mitigation Plan.....CMP 1 to CMP 2

Contract DrawingsUnder Separate Cover

2. Standard Documents – not supplied

- i) (available in the “MMCD – General Conditions, Specifications and Standard Detail Drawings”)
 - Instructions to Tenderers
 - General Conditions
 - Schedule 17.5.3 – Letter Agreement with Referee
 - Flow Chart – Changes and Extra Work
 - Flow Chart – Dispute Resolution
 - Specifications
 - Standard Detail Drawings
- ii) City of Coquitlam Supplementary Specifications for Contract Documents

Invitation to Tender



INVITATION TO TENDER

DATE OF ISSUE: **May 29, 2026**

We acknowledge with gratitude and respect that the name Coquitlam was derived from the hən̓q̓əmi̓n̓əh̓ word kʷikʷə́ləm (kwee-kwuh-tlum) meaning “Red Fish Up the River”. The City is honoured to be located on the kʷikʷə́ləm (Kwikwetlem) traditional and ancestral lands, including those parts that were historically shared with the s̓q̓əciyaʔ t̓əməxʷ (Katzie), and other Coast Salish Peoples.

Tender No. 74747

Quarry Road Enhancements

The City of Coquitlam invites tenders for **Contract 74747 – Quarry Road Enhancements**, generally consisting of the following, but not limited to:

- Culvert replacements and extensions
- 2745mm x 2745mm box culvert installation at Burdett Creek
- Two new wildlife crossings (1800mm x 900mm) concrete box culverts complete with Animex Wildlife Fencing;
- Roadway widening, raising and regrading;
- Asphalt Paving – approx. 5000 tonnes;
- Thermoplastic line painting;
- Environmental restoration, topsoil and seeding; and,
- Other miscellaneous and incidental work as contained in the Contract Documents.

Tender Documents and Drawings are available for downloading from the City of Coquitlam website: www.coquitlam.ca/BidOpportunities

Printing of Tender documents and drawings is the sole responsibility of the Tenderers.

Tenders submitted must be accompanied by a copy of the original specified 10% Bid Bond and will be received:

On or Before 2:00 pm local time

June 19, 2026

("Closing Date and Time")

Addenda

Tenderers are required to check the City's website for any updated information, issued before the Closing Date at: www.coquitlam.ca/BidOpportunities. Where in its sole discretion it considers it to be necessary or desirable, the City may issue Addenda to amend any portion of the Contract Documents.

Any changes to the Tender documentation will be issued by means of written Addenda and posted on the City's website and will form part of the Tender. No amendment of any kind to the Tender is effective unless it is posted in a formal written Addendum on the City website. Upon submitting a Tender, Tenderers will be deemed to have received notice of all Addenda that are posted on the City's website and deemed to have considered the information for inclusion in the Tender submitted.

The City does not retain a bidder's list or bidder's registry. Tenderers are encouraged to register as plan takers and may view the Tender Documents and Drawings by contacting the Vancouver Regional Construction Association (VRCA), website: www.my.vrca.ca, ph: 604-294-3766, or email at vrca@vrca.ca, quoting the Coquitlam Tender Reference Number.

Should there be any discrepancy in the documentation provided, the City's original file copy shall prevail.

Tenders shall remain open for acceptance for 60 days following the submission Closing Date.

The City reserves the right to accept or reject any or all Tenders and the lowest or any Tender may not necessarily be accepted. The City also reserves the right to cancel any request for Tender at any time without recourse by the Tenderer.

The City, prior to award of any Tender, may negotiate with the Tenderer presenting the lowest price compliant Tender, for changes in the Work, materials, specifications or conditions without having any duty or obligation to advise any other Tenderers or to allow them to modify their Tenders, and the City will have no liability to any Tenderer as a result of such negotiations or modifications.

The City will not be responsible for any costs incurred by the Tenderer in preparing the Tender.

Procurement of goods and services is conducted in accordance with Chapter 5 of the Canadian Free Trade Agreement (CFTA) and the New West Partnership Trade Agreement (NWPTA).

M. Pain
Manager Procurement

Instructions to Tenderers

Tender 74747

Quarry Road Enhancements

INSTRUCTIONS TO TENDERERS

TABLE OF CONTENTS	Page
1 Introduction.....	IT 2
2 Tender Documents.....	IT 2 to 3
3 Submission of Tenders.....	IT 3 to 4
4 Additional Instructions to Tenderers.....	IT 4 to 6
5 Tender Requirements	IT 6 to 7
6 Qualifications, Modifications, Alternative Tender	IT 7
7 Approved Equals.....	IT 8
8 Inspection of the Place of the Work.....	IT 8
9 Interpretation of Contract Documents	IT 8 to 9
10 Prices	IT 9
11 Taxes.....	IT 9
12 Amendment of Tenders	IT 9 to 10
13 Duration of Tenders	IT 10
14 Qualifications of Tenders	IT 10
15 Award.....	IT 10 to 13
16 Subcontractors	IT 13
17 Optional Work.....	IT 13

INSTRUCTIONS TO TENDERERS

(FOR USE WHEN UNIT PRICES FORM THE BASIS OF PAYMENT - TO BE USED ONLY WITH THE GENERAL CONDITIONS AND OTHER STANDARD DOCUMENTS OF THE UNIT PRICE MASTER MUNICIPAL CONSTRUCTION DOCUMENTS.)

The City of Coquitlam

Contract: **Quarry Road Enhancements**

Reference No. **74747**

- 1.0 Introduction**
- 1.1 These Instructions apply to and govern the preparation of tenders for this *Contract*. The *Contract* is generally for the following work:
- Culvert replacements and extensions
 - 2745mm x 2745mm box culvert installation at Burdett Creek
 - Two new wildlife crossings (1800mm x 900mm) concrete box culverts complete with Animex Wildlife Fencing;
 - Roadway widening, raising and regrading;
 - Asphalt Paving – approx. 5000 tonnes;
 - Thermoplastic line painting;
 - Environmental restoration, topsoil and seeding; and,
 - Other miscellaneous and incidental work as contained in the Contract Documents.
- 1.2 All inquiries regarding this Tender are to be submitted in writing referencing the **Tender Name and Number** sent to:
- E-mail** bid@coquitlam.ca
- The deadline for inquiries is **12:00 PM** local time, **Tuesday, June 16, 2026**.
- INQUIRIES RECEIVED AFTER THIS DATE AND TIME MAY NOT RECEIVE A RESPONSE.**
- 2.0 Tender Documents**
- 2.1 The Tender Documents which a Tenderer should review to prepare a Tender consist of all of the *Contract Documents* listed in Schedule 1 entitled "Schedule of Contract Documents". Schedule 1 is attached to the Agreement which is included as part of the Tender Package. The *Contract Documents* include the drawings listed in Schedule 2 to the Agreement, entitled "**List of Contract Drawings**".
- 2.2 A portion of the Contract Documents are included by reference. Copies of these documents have not been included with the tender package. These documents are the General Conditions, Specifications and Standard Detail Drawings. They are those

contained in the publication entitled "Master Municipal Construction Documents - General Conditions, Specifications and Standard Detail Drawings". Refer to Schedule 1 to the Agreement or, if not specified in Schedule 1, then the applicable edition shall be the most recent edition as of the date of the *Tender Closing Date*. All sections of this publication are by reference included in the Contract Documents.

2.3 Any additional information made available to Tenderers prior to the Tender Closing Time by the Owner or representative of the Owner, such as geotechnical reports or as-built plans, which is not expressly included in Schedule 1 or Schedule 2 to the Agreement, is not included in the Contract Documents. Such additional information is made available only for the assistance of Tenderers who must make their own judgments about its reliability, accuracy, completeness and relevance to the *Contract*, and neither the Owner nor any representative of the Owner gives any guarantee or representation that the additional information is reliable, accurate, complete or relevant.

3.0 Submission of Tenders

3.1 Tenders must be submitted on the Tender Form provided, accompanied by a copy of the original 10% Bid Bond quoting the Tender Name and Number, and be uploaded to the City's file transfer website.

Tenders must be received on or before:

Tender Closing Time: 2:00 p.m. local time

Tender Closing Date: June 19, 2026

For the purpose of the Tender submission, digital copies of original documents and signatures sent electronically are accepted. Original documents are required upon request by the City.

Instructions for Tender Submission

3.2 **Tender submissions are to be consolidated into one (1) .pdf file and uploaded electronically through QFile, the City's file transfer service accessed at website: <https://qfile.coquitlam.ca/filedrop/purchasing>**

- 1. In the "From" field enter:** Tenderers email address
- 2. In the "Subject" field enter:** Tender Name
- 3. In the "BID Number" field enter:** Tender Number
- 4. In the "Type" field enter:** **New** if this is a new submission or **Update** if this is an updated submission
- 5. Add consolidated Tender files in Adobe PDF format, and Appendix 1 in Microsoft Excel XLS format, and Send** (ensure your web browser remains open until you receive a files sent message. You will also receive an email from QFile confirming the submission)

Tenderers are responsible to allow ample time to complete the Tender submission process. If assistance is required, phone 604-927-3037.

3.3 Tenders submitted shall be deemed to be received when displayed as a new email in the in-box of the above email address. The City will not be responsible for any delay or for any Tenders not received for any reason, including technological delays or issues by either party's network or email program, and the City will not be liable for any damages associated with Tenders not received.

3.4 The City reserves the right to accept late Tenders to allow for technological delays. The City also reserves the right to accept Tenders by email: bid@coquitlam.ca.

BIDS RECEIVED IN-PERSON, BY COURIER, OR BY FAX WILL NOT BE ACCEPTED.

3.5 Tenders will not be opened in public. The unevaluated results will be forwarded to participants by email.

3.6 Tender submissions are subject to the Freedom of Information and Protection of Privacy Act and contents may be disclosed if required to do so, pursuant to the Act.

**4.0 Additional
Instructions to
Tenderers**

Additional Instructions to Tenderers

A WSA Notification has been submitted by the City to the Province. The 45 day period will end on June 27, 2026.

Milestone date for Substantial Performance will be adjusted pro rata if permit issuance is delayed. The Contractor will not be eligible for reimbursement for out of pocket costs incurred due to delay in permit issuance.

The work zone falls within an environmentally sensitive and active area. Refer to Section 01 57 01S for specific project requirements relating to the Water Sustainability Act and Western Toad Migration.

The Contractor is required to be familiar with the requirements for Chance Find Procedures as described in Appendix B.

**Obtaining
Documents**

4.1 The following documents which are referred to and form part of the Contract Document package may be obtained as follows:

- Copies of the Master Municipal Construction Documents Volume II (2009), General Conditions, Specifications and Standard Detail Drawings are available separately from:

Support Services Unlimited
Suite 102
211 Columbia Street
Vancouver, B.C. V6A 2R5
Tel: 604-681-0295

Fax: 604-305-0424

- Copies of the City of Coquitlam Supplementary Specifications and Detailed Drawings to the MMCD 2009 Edition are available for viewing and downloading off the City of Coquitlam website: [Supplementary Specifications and Detailed Drawings to MMCD](#)

Test Excavations	4.2	Prior to the excavation of test holes on road allowances or privately owned property the Tenderer shall obtain permission from the Municipality or Owner of the property and comply with their requirements for restoration of disturbed surfaces and utilities. Failure to comply with Municipal by-laws restricting this practice may result in prosecution of the offending party.
Business License	4.3	The successful Tenderer shall provide evidence of a City of Coquitlam Business License or Tri-Cities Inter-Municipal Business License prior to commencement of work or supply of materials. For more information, contact Business License Division Ph: 604-927-3085 or apply online at website: City of Coquitlam Business License
No Claim	4.4	Except as expressly and specifically permitted in these Instructions to Tenderers, no Tenderer shall have any claim for any compensation of any kind whatsoever, as a result of participating in this Tender, including accepting a non-compliant bid and by submitting a Tender, each Tenderer shall be deemed to have agreed that it has no claim.
No Cost	4.5	The City will not under any circumstances be responsible for any costs incurred by the Tenderer in preparing the Tender.
Right to Accept or Reject any Tender	4.6	<p>The City reserves the right to accept or reject any or all Tenders and the lowest or any Tender may not necessarily be accepted. In its sole discretion, the City may reject or retain for its consideration, tenders which are nonconforming because they do not contain the content or form required by the instructions to tenderers or for failure to comply with the process for submission set out in these instructions to tenderers.</p> <p>The City specifically reserves the right to reject all Tenders if none is considered to be satisfactory and, in that event, at its option, to call for additional Tenders.</p>
Negotiation	4.7	The City, prior to award of any Tender, may negotiate with the Tenderer presenting the lowest price compliant Tender, for changes in the Work, materials, specifications or conditions without having any duty or obligation to advise any other Tenderers or to allow them to modify their Tenders, and the City will have no liability to any Tenderer as a result of such negotiations or modifications.

- Cancellation of Tender** 4.8 The City reserves the right to cancel any request for Tender at any time without recourse by the Tenderer. The City has the right to not award this work for any reason including choosing to complete the work with the City's own forces.
- Conflict of Interest** 4.9 Tenderers shall disclose any actual or potential conflicts of interest and existing business relationships it may have with the City, their elected or appointed officials or employees.
- Collusion** 4.10 Tenderers will not discuss or communicate with one another in regards to the preparation of their Tenders. Each Tenderer will ensure that its participation in the Tender process and that of its team members is conducted without collusion or fraud. Failure to comply with this requirement may lead to disqualification without further notice or warning.
- Instruction to Tenderers – Part II** Delete Instructions to Tenderers – Part II Contained in the Edition of the Publication "Master Municipal Construction Documents 2009" and replace with the following:
- 5.0 Tender Requirements** 5.1 A tender should be on the Form of Tender as provided and be signed by the authorized signatory(s) as follows:
- 5.1.1 if the tenderer is a partnership or joint venture then the name of the partnership or joint venturer should be included, and each partner or joint venturer should sign personally; if a partner of joint venture is a corporation then such corporation should sign as indicated in paragraph 5.1.3 below; and
 - 5.1.2 if the tenderer is a corporation then the full name of the corporation should be included, together with the names and signatures of authorized signatories.
 - 5.1.3 For the purpose of the Tender submission, digital copies of original documents and electronic signatures are accepted. Original documents are required upon request by the City.
- 5.2 A tender must be accompanied by tender security ("*Bid Security*") in the form of:
- 5.2.1 a copy (digital or Electronic copy is acceptable) of the original bid bond in an amount equal to 10% of the Tender Price, issued by a surety licensed to carry on the business of suretyship in British Columbia in a form reasonably satisfactory to the *Owner*;

- 5.3 Tenderer should be competent and capable of performing the various items of work. Tenderer shall complete the following statement sheets appended to the Form of Tender:
- 5.3.1 Appendix 1 – the Schedule of Quantities and Prices;
 - 5.3.2 Appendix 2 – a “*Preliminary Construction Schedule*”, generally in the form attached as Appendix 2 to the Form of Tender, and showing *Substantial Performance* by the date or within the duration, shown in paragraph 2.2 of the Form of Tender.
 - 5.3.3 Appendix 3 – name and brief description of the previous experience of the *Superintendent* the tenderer will use for the *Work*;
 - 5.3.4 Appendix 4 – a list of previous comparable work, including a brief description of that work, approximate contract value, and references (with phone numbers);
 - 5.3.5 Appendix 5 – a complete list of all subcontractors, if any, that the tenderer will use for the *Work* including full names; and
 - 5.3.6 Appendix 7 – is provided for information only, to indicate the Contract Insurance is to be submitted by the successful Tenderer upon Notice of Award.
- 5.4 The successful tenderer will, within 15 *Days* of receipt of the written *Notice of Award*, be required to deliver to the *Owner* the items listed in FT 5.1.1, including a Performance Bond and a Labour and Material Payment Bond as described in FT 5.1.1(a), failing which the provisions of FT 6.1 will apply.

**6.0 Qualifications,
Modifications,
Alternative
Tenders**

- 6.1 Tenders which contain qualifications, or omissions, so as to make comparison which other tenders difficult, may be rejected by the *Owner*.
- 6.2 A tenderer may, at the tenderer’s election, submit an alternative tender (“*Alternative Tender*”) which varies the materials, products, designs or equipment by the *Owner as Approved Equals* as the case may be, but an *Alternative Tender* must be in addition to, and not in substitution for a tender which conforms to the requirements of the *Contract Documents*.
- 6.3 The only *Alternative Tender* that the *Owner* may accept is an *Alternative Tender* submitted by that tenderer whose conforming tender, submitted as required by paragraph 6.2 of these Instructions to Tenderers, would have been accepted by the *Owners* in the preference to other conforming tenders, if no *Alternative Tenders* had been invited.

- 7.0 Approved Equals**
- 7.1 Prior to the *Tender Closing Time and Date*, a tenderer may request the *Owner* to approve materials, products, or equipment ("*Approved Equal*") to be included in a tender in substitution for items indicated in the Contract Documents.
- 7.2 Applications for an *Approved Equal* must be in writing, and supported by appropriate supporting information, data, specifications, and documentation.
- 7.3 If the *Owner* decides in its discretion to accept an *Approved Equal*, then the *Owner* will issue an addendum to all tenderers.
- 7.4 The *Owner* is not obligated to review or accept an application for an *Approved Equal*.
- 8.0 Inspection of the Place of the Work**
- 8.1 All tenderers, either personally or through a representative, are responsible to examine the *Place of the Work* before submitting a tender. A tenderer has full responsibility to be familiar with and make allowance in the tender for all conditions at the *Place of the Work* that might affect the tender, including any information regarding subsurface soil conditions made available by the *Owner*, the location of the *Work*, local conditions, topographical soil conditions, weather and access. Unless otherwise specified in the *Contract Documents*, a tenderer is not required to do subsurface investigations. By submitting a tender, a tenderer represents that the tenderer has examined the *Place of the Work*, or specifically elected not to. No additional payments or time extensions shall be claimable or due because of difficulties relating to conditions at the *Place of the Work* which were reasonably foreseeable by a contractor qualified to undertake the *Work*.
- 8.2 Tenderers are referred to GC 11.2.1 regarding **Concealed or Unknown Conditions**.
- 9.0 Interpretation of Contract Documents**
- 9.1 If a tenderer is in doubt as to the correct meaning of any provision of the *Contract Documents*, the tenderer may request clarification as instructed in paragraph 1.2 of the Instructions to Tenderers.
- 9.2 If a tenderer discovers any contradictions or inconsistencies in the *Contract Documents* or its provisions, or any discrepancies between a provision of the *Contract Documents* and conditions at the *Place of the Work as* observed in an examination under paragraph 8 of the person named in paragraph 1.2 of the Instructions to Tenderers.
- 9.3 If the *Owner* considers it necessary, the *Owner* may issue written addenda to provide clarification (s) of the *Contract Documents*.

- 9.4 No oral interpretation or representations from the *Owner* or any representative of the *Owner* will affect, alter, or amend any provision of the *Contract Documents*.
- 10.0 Prices**
- 10.1 The Tendered Price will represent the entire cost excluding *GST* to the *Owner* of the complete *Work* based on the estimated quantities in the *Schedule of Quantities and Prices* of the Form of Tender. Notwithstanding the generalities of the above, tenderers shall include in the tendered prices (including unit prices, lump sum prices, or other forms of pricing) sufficient amounts to cover:
- 10.1.1 the costs of all labour, equipment and material included in or required for the *Work*, including all items which, whole not specifically listed in the *Schedule of Quantities and Prices*, are included in the *Work* specifically or by necessary inference from the *Contract Documents*;
 - 10.1.2 all assessments payable with respect to labour as required by any statutory scheme such as unemployment insurance, holiday pay, insurance, CPP and all employee benefits and the Workers Compensation Act;
 - 10.1.3 all overhead costs, including head office and on-site overhead costs, and all amounts for the *Contractor's* profit.
- 10.2 The tendered prices and all subcontracts must allow for compliance with all applicable laws regarding trade or other qualifications of employees performing the *Work*, and payment of appropriate wages for labour included in or required for the *Work*.
- 11.0 Taxes**
- 11.1 The tendered prices shall cover all taxes and assessments of any kind payable with respect to the *Work*, but shall not include *GST*. *GST* shall be listed as a separate line item as required by GC 19.3.
- 12.0 Amendment of Tenders**
- 12.1 A tenderer may amend or revoke a tender by giving written notice, delivered by Email, to the office referred to in paragraph 3.4 of the Instructions to Tenderers at any time up until the *Tender Closing Date and Time*. An amendment or revocation that is received after the *Tender Closing Date and Time* shall not be considered and shall not affect a tender as submitted.
- 12.2 An amendment or revocation must be signed by an authorized signatory of the tenderer in the same manner as provided by paragraph 5.1 of these Instructions to Tenderers.

12.3 Any amendment that expressly or by inference discloses the tenderer's *Tender Price* or other material element of the tender such that, in the opinion of the *Owner*, the confidentiality of the tender is breached, will invalidate the entire tender.

12.4 An acceptable form of a tender amendment which tenderers may, but are not required to, use is as follows:

"Contract: _____
(TITLE OF CONTRACT)
Reference No. _____
(OWNER'S CONTRACT REFERENCE NO.)
TO: _____
(NAME OF OWNER)

We the undersigned wish to amend our tender which we submitted for the above *Contract* by deleting the following tendered prices or items from our tender:

(TENDERED PRICES AND/OR TENDER ITEMS IN THE TENDER THAT ARE TO BE AMENDED)

and substituting the following revised tendered prices or items:

(REVISED TENDERED PRICES OR TENDER ITEMS)

The extensions in our tender should be adjusted accordingly, and our ***Tender Price*** as set out in Appendix 1 of our submitted **Form of Tender**, and on the ***Schedule of Quantities and Prices***, increased / decreased by \$_____, excluding GST. We have not included our revised ***Tender Price*** in order to preserve the confidentiality of our tender.

Signed and delivered the ___ day of _____, 20__."

13.0 Duration of Tenders

13.1 After the *Tender Closing Time*, a tender shall remain valid and irrevocable as set out in paragraph 5.1 of the Form of Tender.

14.0 Qualifications of Tenderers

14.1 By submitting a tender, a tenderer is representing that it has the competence, qualifications and relevant experience required to do the *Work*.

15.0 Award

15.1 In exercising its discretion, the *Owner* will have regard to the information provided in the Appendices to the Form of Tender as

described under IT 5.3 including the proven experience of the tenderer, and any listed subcontractors, to do the *Work*.

Tenders received will be evaluated to provide the City with greatest value based on quality, service, price and experience. Evaluation Criteria will include but is not limited to:

1. Ability to meet specifications and required completion date
2. Contractor's past experience, references, reputation and compliance to specifications
3. Demonstrated successful experience on similar projects and specific equipment installation
4. Price: purchase price, maintenance costs, availability of parts and service, warranty and compatibility with existing equipment and/or conditions
5. Any other criteria, the City deems, at its sole discretion, necessary to evaluate Tenders;
6. Lowest price will not necessarily be accepted.

The City may, in its absolute discretion, not award to a Tenderer if the Tenderer, or any officer or director of a corporate Tenderer, is or has been engaged, either directly or indirectly through another corporation or legal entity, in a legal action against the City and its elected and appointed officers and employees or any of them in relation to:

- a) any other contract or services; or
- b) any matter arising from the City's exercise of its powers, duties or functions under the *Local Government Act*, the *Community Charter* or any other enactments; within five years of this Tender Offer.

For purposes of this section, the words "legal action" includes, without limitation, mediation, arbitration, hearing before an administrative tribunal or lawsuit filed in any court.

Without limiting the City's sole discretion, in determining whether or not to award to a Tenderer pursuant to this clause, the City will consider such factors as whether the legal action is likely to affect the Tenderer's ability to work with the City and its employees, agents, consultants and representatives or any of them and whether the City's past experience with the Tenderer in the matter that resulted in the legal action indicates that the City is likely to incur increased staff and legal costs or either of them in the administration of this contract if it is awarded to the Tenderer.

In the event that the lowest total Tender Price by two or more Tenderers is the same amount, the City will select a Tenderer with an overall satisfactory performance record in having completed

work on previous relevant projects that are provided as references, and on City projects. Information obtained from references will not be disclosed or discussed with any Tenderer. If all references are equal, selection will be determined by a coin toss in a manner to be directed by the City.

Where only one Tender is received the City may reject such and re-tender on a selected basis.

15.2 The *Owner* will notify the successful tenderer in writing.

15.3 If there are any discrepancies in the *Schedule of Quantities and Prices* between the unit prices and the extended totals then the unit prices shall be deemed correct, and corresponding corrections shall be made to the extended totals. If a unit price or extended total has been omitted, the following shall apply:

- a) If a unit price is given but the corresponding extended total has been omitted, then the extended total shall be calculated from unit price and the estimated quantity, and inserted as the extended total;
- b) If an extended total is given but the corresponding unit price has been omitted, then the unit price shall be calculated from the extended total and estimated quantity, and inserted as the unit price;
- c) If both the unit price and the corresponding extended total for a tender item have been omitted, then the following test shall be applied to determine whether the tender shall be rejected as incomplete:
 - (i) the highest of the unit prices tendered by other tenderers for that tender item shall be used as the test unit price, and the corresponding test extended total shall be calculated from the test unit price and the estimated quantity;
 - (ii) if the test extended total for the tender item exceeds 1% of the revised total *Tender Price*, including the test extended total, or if the revised total *Tender Price*, including the test extended total, alters the ranking of the tenderers according to the lowest *Tender Price*, then the omitted unit price for that tender item is deemed to materially affect the *Tender Price* relative to other tenders and the tender shall be rejected;
 - (iii) if the tender is not rejected under subparagraph (ii) of this IT 15.3 (c), then the unit price and the extended total for that tender item shall both be deemed to be, and the costs for that tender item

shall be zero deemed to be included in other tender items prices;

- d) In no event shall page totals in the *Schedule of Quantities and Prices* or the total *Tender Price* be used to calculate missing extended totals or unit prices.

- 16.0 Subcontractors**
- 16.1 The *Owner* reserves the right to object to any of the subcontractors listed in a tender. If the *Owner* objects to any of the subcontractor(s) then the *Owner* will permit a tenderer to, within 5 days, propose a substitute subcontractor(s) acceptable to the *Owner* provided that there is not resulting adjustment in the *Tender Price* or the completion date set out in paragraph 2.2 of the Form of Tender. A tenderer will not be required to make such substitution and, if the *Owner* objects to a listed *Subcontractor(s)*, the tenderer may, rather than propose a substitute subcontractor(s), consider its tender rejected by the *Owner* and by written notice withdraw it tender. The *Owner* shall, in the event, return the tenderer's bid security.
- 17.0 Optional Work**
- 17.1 If the *Schedule of Quantities and Prices* includes any tender prices for *Optional or Provisional Work*, as defined in GC 7.4.1, the tenderers must complete all the unit prices for such *Optional or Provisional Work*. Such tender prices shall not include any general overhead costs, or other costs, or profit, not directly related to the *Optional or Provisional Work*.
- 17.2 Notwithstanding that the *Owner* may elect not to proceed with the *Optional or Provisional Work*, the tender prices for any *Optional or Provisional Work*, including the extended totals for *Optional or Provisional Work* unit prices, shall be included in the *Tender Price* for the purpose of any price comparisons between tenders.

Form of Tender



Form of Tender

Tender No. 74747

Quarry Road Enhancements

Summary

Name of **Contractor**: _____

Tender Price (exclude GST): \$ _____

(FROM APPENDIX 1 OF FORM OF TENDER)

Tender submitted must be accompanied by a copy of the original 10% Bid Bond and will be received

**On or before 2:00 pm (local time)
Friday, June 19, 2026**

Instructions for Tender Submission

Tender submissions are to be consolidated into one (1) .pdf file and uploaded electronically through QFile, the City's file transfer service accessed at website:

<https://qfile.coquitlam.ca/filedrop/purchasing>

- 1. In the "From" field enter:** Tenderers email address
- 2. In the "Subject" field enter:** Tender Name
- 3. In the "BID Number" field enter:** Tender Number
- 4. In the "Type" field enter:** **New** if this is a new submission or **Update** if this is an updated submission
- 5. Add consolidated Tender files in Adobe PDF format, and Appendix 1 in Microsoft Excel XLS format, and Send** (ensure your web browser remains open until you receive a files sent message. You will also receive an email from QFile confirming the submission)

Tenderers are responsible to allow ample time to complete the Tender submission process. If assistance is required, phone 604-927-3037.

May 2026

The City of Coquitlam
3000 Guildford Way
Coquitlam, B.C. V3B 7N2

(FOR USE WHEN UNIT PRICES FORM THE BASIS OF PAYMENT - TO BE USED ONLY WITH THE GENERAL CONDITIONS AND OTHER STANDARD DOCUMENTS OF THE UNIT PRICE MASTER MUNICIPAL CONSTRUCTION DOCUMENTS.)

Contract Name: Quarry Road Enhancements
Reference No.: 74747

TO OWNER:

1 WE, THE UNDERSIGNED:

- 1.1 have received and carefully reviewed all of the *Contract Documents*, including the Instructions to Tenderers, the City of Coquitlam Supplementary General Conditions, the City of Coquitlam Supplementary Contract Specifications, the specified edition of the "Master Municipal Construction Documents – General Conditions, Specifications and Standard Detail Drawings" and the following Addenda:

_____;

(ADDENDA, IF ANY)

- 1.2 shall fully disclose any actual or potential conflicts of interest and existing business relationships we may have with the City, their elected or appointed officials or employees:

- 1.3 have full knowledge of the *Place of the Work*, and the *Work* required; and
1.4 have complied with the Instructions to Tenderers; and

2 ACCORDINGLY WE HEREBY OFFER:

- 2.1 to perform and complete all of the *Work* and to provide all the labour, equipment and material all as set out in the *Contract Documents*, in strict compliance with the *Contract Documents*; and
2.2 to achieve *Substantial Performance* of the *Work* on or before **October 31, 2026**; and
2.3 to do the *Work* for the price, which is the sum of the products of the actual quantities incorporated into the *Work* and the appropriate unit prices set out in Appendix 1, the "*Schedule of Quantities and Prices*", plus any lump sums or specific prices and adjustment amounts as provided by the *Contract Documents*. For the purposes of tender comparison, our offer is to complete the *Work* for the "*Tender Price*" as set out on Appendix 1 of this Form of Tender. Our *Tender Price* is based on the estimated quantities listed in the *Schedule of Quantities and Prices*, and excludes *GST*.

3 WE CONFIRM:

- 3.1 that we understand and agree that the quantities as listed in the *Schedule of Quantities and Prices* are estimated, and that the actual quantities will vary.
- 3.2 that we understand and agree that the owner is in no way obliged to accept this Tender.

4 WE CONFIRM:

- 4.1 that the following Appendices are attached to and form a part of this tender:
 - 4.1.1 the Appendices as required by paragraph 5.3 of the Instructions to Tenderers - Part II; and
 - 4.1.2 the *Bid Security* as required by paragraph 5.2 of the Instructions to Tenderers - Part II.
 - 4.1.3 the Certificate of Compliance on the form provided in Appendix 7 of this Form of Tender.

5 WE AGREE:

- 5.1 that this tender will be irrevocable and open for acceptance by the *Owner* for a period of **60** calendar days from the day following the *Tender Closing Date and Time*, even if the tender of another Tenderer is accepted by the *Owner*. If within this period the *Owner* delivers a written notice ("*Notice of Award*") by which the *Owner* accepts our tender we will:
 - 5.1.1 within **15 Days** of receipt of the written *Notice of Award* deliver to the *Owner*:
 - a) a Performance Bond and a Labour and Material Payment Bond, each in the amount of 50% of the *Contract Price*, issued by a surety licensed to carry on the business of suretyship in the province of British Columbia, and in a form acceptable to the *Owner*;
 - b) a "clearance letter" indicating that the Tenderer is in WCB compliance; and
 - c) a copy of the insurance policies as specified in SGC Section 24 indicating that all such insurance coverage is in place and;
 - d) a letter confirming the *Contractor* as "Prime Contractor" for the Contract as specified in SGC Section 21.2.1.
 - 5.1.2 within **2 Days** of receipt of written "*Notice to Proceed*", or such longer time as may be otherwise specified in the *Notice to Proceed*, commence the *Work*; and
 - 5.1.3 sign the Contract Documents as required by GC 2.1.

6 WE AGREE:

6.1 that, if we receive written *Notice of Award* of this *Contract* and, contrary to paragraph 5 of this Form of Tender, we:

6.1.1 fail or refuse to deliver the documents as specified by paragraph 5.1.1 of this Form of Tender; or

6.1.2 fail or refuse to commence the *Work* as required by the *Notice to Proceed*,

then such failure or refusal will be deemed to be a refusal by us to enter into the *Contract* and the *Owner* may, on written notice to us, award the *Contract* to another party. We further agree that, as full compensation on account of damages suffered by the *Owner* because of such failure or refusal, the *Bid Security* shall be forfeited to the *Owner*, in an amount equal to the lesser of:

6.1.3 the face value of the *Bid Security*; and

6.1.4 the amount by which our *Tender Price* is less than the amount for which the *Owner* contracts with another party to perform the *Work*.

7 OUR ADDRESS is as follows:

Phone: _____ - _____ - _____

Email: _____

Attention: _____

This Tender is executed this _____ day of _____, 20____.

Contractor:

(FULL LEGAL NAME OF CORPORATION, PARTNERSHIP OR INDIVIDUAL)

(AUTHORIZED SIGNATORY)

(AUTHORIZED SIGNATORY)

8 WE CONFIRM:

8.1 our Goods and Services Tax (GST) registration status is as follows:

8.1.1 for information purposes, our GST Registration Number is:

(GST REGISTRATION NUMBER)

or;

8.1.2 by signature hereunder, we certify we are **not required** to provide a registration number:

(AUTHORIZED SIGNATORY)

(AUTHORIZED SIGNATORY)

Appendix 1
FORM OF TENDER
Contract 74747
Quarry Road Enhancements

SCHEDULE OF QUANTITIES AND PRICES

(see paragraph 5.3.1 of the Instruction to Tenderers)

(All prices and quotations including the Contract Prices shall Exclude GST)

(Should there be any discrepancy in the information provided, the City's original file copy shall prevail)

ITEM NO.	MMCD Ref./ (Supplementary Contract Specifications)	DESCRIPTION	UNIT	QUANTITY	UNIT PRICE	EXTENDED AMOUNT
1.00	01 53 015	TEMPORARY FACILITIES				
1.01	(1.6.2)	Dewatering and Site Isolation - Provisional		Allowance		\$100,000.00
2.00	01 57 015	ENVIRONMENTAL PROTECTION				
2.01	(1.6.1)	ESC Supply and Installation, Maintenance and Removal		Allowance		\$100,000.00
2.02	(1.6.2)	Western Toad Environmental Protection		Allowance		\$75,000.00
3.00	01 58 015	PROJECT IDENTIFICATION				
3.01	(1.3.1)	Construction Zone Information Signs	each	4		
4.00	03 40 015	PRECAST CONCRETE				
4.01	(1.4.3)	Concrete Lock Block Retaining Wall	sq.m	150		
4.02	1.4.4	Concrete Roadside Barriers (BC MoTT SP941-01)	lin.m	850		
5.00	31 05 175	AGGREGATES AND GRANULAR MATERIALS				
5.01	(1.4.1)	75mm Minus Pit Run	tonne	5,000		
6.00	31 11 015	CLEARING AND GRUBBING				
6.01	(1.4.1)	Clearing and Grubbing	LS	1		
7.00	31 22 165	RESHAPING GRANULAR ROAD BEDS				
7.01	(1.4.1)	Reshaping	sq.m	14,500		
8.00	31 23 17	ROCK REMOVAL				
8.01	1.6.4	Rock Removal - Provisional	cu.m	20		
9.00	31 23 015	EXCAVATING, TRENCHING AND BACKFILLING				
9.01	(1.10.3)	Over Excavation - Provisional	cu.m	30		
9.02	(1.10.6)	Reshaping of Existing Ditch or Channel (including Offsite Disposal) for Culvert Works	cu.m	500		
9.03	(1.10.9)	Ditch Block	each	2		
10.00	31 24 135	ROADWAY EXCAVATION, EMBANKMENT AND COMPACTION				
10.01	(1.8.4)	Remove Existing Asphalt Driveway	sq.m	15		
10.02	(1.8.4)	Remove Existing Lock Block Walls	LS	1		
10.03	(1.8.5)	Common Excavation (Offsite Disposal)	cu.m	5,500		
10.04	(1.8.5)	Ditch Shaping	cu.m	1,000		
11.00	31 32 19	GEOSYNTHETICS				
11.01	1.6.1	Non-woven Geotextile Underlay (Terrafix 420R or Approved Equivalent)	sq.m	400		
12.00	31 37 105	RIP RAP				
12.01	(1.4.1)	Uniform Rip Rap (Class 25, 25kg)	tonne	400		
12.02	(1.4.1)	0.6-1.0m Semi Rounded Boulders for Rock Weir	each	20		
12.03	(1.4.1)	Engineered Streambed Mix	cu.m	15		
13.00	32 11 16.15	GRANULAR SUBBASE				
13.01	(1.4.3)	75mm Minus Granular Subbase	tonne	2,750		
14.00	32 11 235	GRANULAR BASE				
14.01	(1.4.3)	19mm Minus Granular Base	tonne	5,500		
15.00	32 12 13.15	ASPHALT TACK COAT				
15.01	(1.5.1)	Asphalt Tack Coat	sq.m	14,500		
16.00	32 12 165	HOT-MIX ASPHALT CONCRETE PAVING				
16.01	(1.5.1 / 1.5.9)	Machine Laid Asphaltic Concrete Paving - MMCD Lower Course #1 - 1 lift (75mm)	tonne	3,000		
16.02	(1.5.1 / 1.5.9)	Machine Laid Asphaltic Concrete Paving - MMCD Upper Course #1 - 1 lift (50mm)	tonne	2,000		
16.03	(1.5.3 / 1.5.9)	Asphalt Driveways - MMCD Upper Course #2 (60mm)	sq.m	15		

ITEM NO.	MMCD Ref./ (Supplementary Contract Specifications)	DESCRIPTION	UNIT	QUANTITY	UNIT PRICE	EXTENDED AMOUNT
16.04	(1.5.3/1.5.9)	Asphalt Drainage Swale	sq.m	350		
17.00	32 17 235	PAINTED PAVEMENT MARKINGS				
17.01	(1.5.3)	Supply and Installation of Thermoplastic Pavement Markings and as shown in the Contract Drawings	L.S.	1		
17.02	(1.5.4.1)	Install New Sign and Post (Roadway or Roadside Barrier)	each	1		
17.03	(1.5.4.2)	Relocate Existing Sign	each	1		
18.00	32 31 135	CHAIN LINK FENCES AND GATES				
18.01	(1.5.5)	Animex Wildlife Fencing (40 " - AMX-SP)	lin.m	250		
19.00	32 91 215	TOPSOIL AND FINISH GRADING				
19.01	(1.4.1)	Imported Topsoil (150mm thick)	sq.m	7,500		
20.00	32 92 19	HYDRAULIC SEEDING				
20.01	1.8	Hydraulic Seeding (Coastal Reclamation Mix) including Straw	sq.m	7,500		
21.00	32 93 015	PLANTING OF TREES, SHRUBS AND GROUND COVERS				
21.01	(1.9.1)	Riparian Restoration	Allowance			\$75,000.00
22.00	33 42 135	PIPE CULVERT				
22.01	(1.5.2)	Supply and Install - 600mm Conc. Culvert - All Depths	lin.m	18		
22.02	(1.5.2)	Supply and Install - 675mm Conc. Culvert - All Depths	lin.m	30		
22.03	(1.5.2)	Supply and Install - 750mm Conc. Culvert - All Depths	lin.m	14		
22.04	(1.5.2)	Supply and Install - 900mm Conc. Culvert - All Depths	lin.m	15		
22.05	(1.5.2)	Culvert Pipe Extension - 375mm Conc. Culvert - All Depths	lin.m	4		
22.06	(1.5.2)	Culvert Pipe Extension -600mm CSP Culvert - All Depths	lin.m	2		
22.07	(1.5.2)	Culvert Pipe Extension- 600mm Conc. Culvert - All Depths	lin.m	1		
22.08	1.5.3	Concrete Headwall 11-13	each	4		
22.09	1.5.3	Concrete Headwall 14-15	each	3		
22.10	(1.5.7)	Supply and Install Box Culvert - All Depths (2745mm x 2745mm c/w baffles and engineered substrate as shown on Contract Drawings) at Burdett Creek- Complete	LS	1		
22.11	(1.5.7)	Supply and Install Box Culvert - All Depths (1800mm x 900mm c/w 300mm thick organic emedment layer as shown on Contract Drawings) at Wildlife Crossings - Complete	LS	2		

Total Tendered Price (exclude GST): _____
(Transfer the amount to Form of Tender Summary Page 1)

Name of Contractor: _____

APPENDIX 2

FORM OF TENDER

**Contract 74747
 Quarry Road Enhancements**

PRELIMINARY CONSTRUCTION SCHEDULE
 (See paragraph 5.3.2 of the Instructions to Tenderers)

INDICATE SCHEDULE WITH BAR CHART WITH CONSTRUCTION DURATIONS

CONSTRUCTION ACTIVITY	JULY		AUGUST				SEPTEMBER				OCTOBER			
	3	4	1	2	3	4	1	2	3	4	1	2	3	4

Substantial Completion Date: **October 31, 2026**

Proposed Disposal Site: _____

APPENDIX 3

FORM OF TENDER

**Contract 74747
Quarry Road Enhancements**

EXPERIENCE OF SUPERINTENDENT

(See paragraph 5.3.3 of the Instructions to Tenderers)

Proposed Project Superintendent _____

List of Project Experience

PROJECT:		Dates:	
Work Description:			
Responsibility:			
Owner/Reference:		Phone No.:	

PROJECT:		Dates:	
Work Description:			
Responsibility:			
Owner/Reference:		Phone No.:	

PROJECT:		Dates:	
Work Description:			
Responsibility:			
Owner/Reference:		Phone No.:	

APPENDIX 4

FORM OF TENDER

**Contract 74747
Quarry Road Enhancements**

CONTRACTOR'S COMPARABLE WORK EXPERIENCE
(See paragraph 5.3.4 of the Instructions to Tenderers)

PROJECT:		VALUE (\$):	
OWNER:		Phone No.:	
Work Description:			

PROJECT:		VALUE (\$):	
OWNER:		Phone No.:	
Work Description:			

PROJECT:		VALUE (\$):	
OWNER:		Phone No.:	
Work Description:			

PROJECT:		VALUE (\$):	
OWNER:		Phone No.:	
Work Description:			

APPENDIX 5

FORM OF TENDER

**Contract 74747
Quarry Road Enhancements**

SUBCONTRACTORS

(See paragraph 5.3.5 of the Instructions to Tenderers)

Trade:		Tender Item:	
Work Description:			
Subcontractor:		Phone No.:	

Trade:		Tender Item:	
Work Description:			
Subcontractor:		Phone No.:	

Trade:		Tender Item:	
Work Description:			
Subcontractor:		Phone No.:	

Trade:		Tender Item:	
Work Description:			
Subcontractor:		Phone No.:	

Trade:		Tender Item:	
Work Description:			
Subcontractor:		Phone No.:	

APPENDIX 6

FORM OF TENDER

**Contract 74747
Quarry Road Enhancements**

Bid Bond

NO. _____

\$ _____

KNOW ALL MEN BY THESE PRESENTS THAT

As Principal, hereinafter called the Principal, and

As Surety, hereinafter called the Surety, are held and firmly bound unto

As Obligee, hereinafter called the Obligee, in the amount of

_____ Dollars (\$_____) lawful money of
Canada, for the payment of which sum, well and truly to be made, the Principal and the Surety bind
themselves, their heirs, executors, administrators, successors and assigns, jointly and severally, firmly by these
presents.

WHEREAS, the Principal has submitted a written Tender to the Obligee, dated the _____ day of
_____, 2026, for Contract _____.

NOW, THEREFORE, THE CONDITION OF THIS OBLIGATION is such that if the aforesaid Principal shall have the
Tender accepted within sixty (60) days from the Closing Date of Tender and the said Principal will, within the
time required, enter into a formal contract and give good and sufficient bonds to secure the performance of
the terms and conditions of the Contract, then this obligation shall be null and void; otherwise the Principal
and Surety will pay unto the Obligee the difference in money between the amount of the bid of the said
Principal and the amount for which the Obligee legally contracts with another party to perform the work if the
latter amount be in excess of the former.

The Surety shall not be liable for a greater sum than the specified penalty of this Bond.

Any suit under this Bond must be instituted before the expiration of six (6) months from the date of this Bond.

IN TESTIMONY WHEREOF, the Principal has hereto set its hand and affixed its seal, and the Surety has caused
these presents to be sealed with its corporate seal duly attested by the signature of its Attorney-In-Fact,
this _____ day of _____, 2026.

SIGNED, SEALED AND DELIVERED

In the presence of:

_____)	_____
_____)	PRINCIPAL
_____)	
_____)	_____
_____)	SURETY

APPENDIX 7

FORM OF TENDER

**Contract 74747
Quarry Road Enhancements**

CERTIFICATE OF COMPLIANCE for CONTRACT INSURANCE

This is provided for information to certify that the Tenderer does hereby undertake and agree to supply to the City of Coquitlam, upon award, contract insurance listed below for the project requirements indicated:

Contract Number: 74747

Contract Name: Quarry Road Enhancements

Description of Work:

- Culvert replacements and extensions
- 2745mm x 2745mm box culvert installation at Burdett Creek
- Two new wildlife crossings (1800mm x 900mm) concrete box culverts complete with Animex Wildlife Fencing;
- Roadway widening, raising and regrading;
- Asphalt Paving – approx. 5000 tonnes;
- Thermoplastic line painting;
- Environmental restoration, topsoil and seeding; and,
- Other miscellaneous and incidental work as contained in the Contract Documents.

Commercial General Liability: \$5,000,000 limit

Special Coverage Required:

<u>YES</u>	<u>NO</u>	<u>Special Coverage Description</u>
()	(X)	Shoring and Underpinning Hazard
()	(X)	Pile Driving and Vibrations
()	(X)	Excavation Hazard
()	(X)	Demolition
()	(X)	Blasting

We also certify that the insurance coverage will meet the requirements of the Supplementary General Conditions Section 24 – Insurance, included as part of the Contract Documents, and that the proof of insurance will be provided on the City of Coquitlam Certificate of Insurance form, without amendments, except for the exclusions noted above.

Name of Tenderer (printed)

Authorized Signature

Date

Agreement

AGREEMENT

Between Owner and Contractor

(FOR USE WHEN UNIT PRICES FORM THE BASIS OF PAYMENT - TO BE USED ONLY WITH THE GENERAL CONDITIONS AND OTHER STANDARD DOCUMENTS OF THE UNIT PRICE MASTER MUNICIPAL CONSTRUCTION DOCUMENTS.)

THIS AGREEMENT made in duplicate this ____ day of _____ 2026.

Contract: Quarry Road Enhancements

Reference No. 74747

BETWEEN:

The City of Coquitlam
3000 Guildford Way
Coquitlam, B.C. V3B 7N2

(the "Owner")

AND:

(the "Contractor")

The *Owner* and the *Contractor* agree as follows:

1 THE WORK - START/COMPLETION DATES

- 1.1 The *Contractor* will perform all *Work* and provide all labour, equipment and material and do all things strictly as required by the *Contract Documents*.
- 1.2 The *Contractor* will commence the *Work* in accordance with the *Notice to Proceed*. The *Contractor* will proceed with the *Work* diligently, will perform the *Work* generally in accordance with the construction schedules as required by the *Contract Documents* and will achieve *Substantial Performance* of the *Work* on or before **October 31, 2026**, subject to the provisions of the *Contract Documents* for adjustments to the *Contract Time*.
- 1.3 Time shall be the essence of the Contract.

2 CONTRACT DOCUMENTS

- 2.1 The "*Contract Documents*" consist of the documents listed or referred to in Schedule 1, entitled "*Schedule of Contract Documents*", which is attached and forms a part of this Agreement, and includes any and all additional and amending documents issued in accordance with the provisions of the *Contract Documents*. All of the *Contract Documents* shall constitute the entire *Contract* between the *Owner* and the *Contractor*.
- 2.2 The *Contract* supersedes all prior negotiations, representations or agreements, whether written or oral, and the *Contract* may be amended only in strict accordance with the provisions of the *Contract Documents*.

3 CONTRACT PRICE

- 3.1 The price for the *Work* ("*Contract Price*") shall be the sum in Canadian dollars of the following:
- a) the product of the actual quantities of the items of *Work* listed in the *Schedule of Quantities and Prices* which are incorporated into or made necessary by the *Work* and the unit prices listed in the *Schedule of Quantities and Prices*; plus
 - b) all lump sums, if any, as listed in the *Schedule of Quantities and Prices*, for items relating to or incorporated into the *Work*; plus
 - c) any adjustments, including any payments owing on account of *Changes* and agreed to *Extra Work*, approved in accordance with the provisions of the *Contract Documents*.
- 3.2 The *Contract Price* shall be the entire compensation owing to the *Contractor* for the *Work* and this compensation shall cover and include all profit and all costs of supervision, labour, material, equipment, overhead, financing, and all other costs and expenses whatsoever incurred in performing the *Work*.

4 PAYMENT

- 4.1 Subject to applicable legislation and the provisions of the *Contract Documents*, the *Owner* shall make payments to the *Contractor*.
- 4.2 If the *Owner* fails to make payments to the *Contractor* as they become due in accordance with the terms of the *Contract Documents* then interest calculated at 2% per annum over the prime commercial lending rate of the Royal Bank of Canada on such unpaid amounts shall also become due and payable until payment. Such interest shall be calculated and added to any unpaid amounts monthly.

5 RIGHTS AND REMEDIES

- 5.1 The duties and obligations imposed by the *Contract Documents* and the rights and remedies available hereunder shall be in addition to and not a limitation of any duties, obligations, rights and remedies otherwise imposed or available by law.

5.2 Except as specifically set out in the *Contract Documents*, no action or failure to act by the *Owner*, *Contract Administrator* or *Contractor* shall constitute a waiver of any of the parties' rights or duties afforded under the *Contract*, nor shall any such action or failure to act constitute an approval of or acquiescence in any breach under the *Contract*.

6 NOTICES

6.1 Communications among the *Owner*, the *Contract Administrator* and the *Contractor*, including all written notices required by the *Contract Documents*, may be delivered by email, or by hand, or by pre-paid registered mail to the addresses as set out below:

The *Owner*:

The City of Coquitlam
3000 Guildford Way
Coquitlam, B.C. V3B 7N2

Tel: 604-927-3500

The *Contractor*:

Tel:
Email:
Attention:

The *Contract Administrator*:

The City of Coquitlam
3000 Guildford Way
Coquitlam, B.C. V3B 7N2

Tel:
Email:
Attention:

6.2 A communication or notice that is addressed as above shall be considered to have been received:

- a) immediately upon delivery, if delivered by hand; or
- b) immediately upon transmission if sent or received by email; or
- c) after 5 days from date of posting if sent by registered mail.

6.3 The *Owner* or the *Contractor* may, at any time, change its address for notice by giving written notice to the other at the address then applicable. Similarly if the *Contract Administrator* changes its address for notice then the *Owner* will give or cause to be given written notice to the *Contractor*.

7 GENERAL

7.1 This *Contract* shall be construed according to the laws of British Columbia.

- 7.2 The *Contractor* shall not, without the express written consent of the *Owner*, assign this *Contract*, or any portion of this *Contract*.
- 7.3 The headings included in the *Contract Documents* are for convenience only and do not form part of this *Contract* and will not be used to interpret, define or limit the scope or intent of this *Contract* or any of the provisions of the *Contract Documents*.
- 7.4 A word in the *Contract Documents* in the singular includes the plural and, in each case, vice versa.
- 7.5 This agreement shall enure to the benefit of and be binding upon the parties and their successors, executors, administrators and assigns

IN WITNESS WHEREOF the parties hereto have executed this Agreement the day and year first written above.

Contractor:

(FULL LEGAL NAME OF CORPORATION, PARTNERSHIP OR INDIVIDUAL)

(AUTHORIZED SIGNATORY)

(AUTHORIZED SIGNATORY AND POSITION - PRINT)

Owner:

The City of Coquitlam

Edwin Dela Rosa, ASCT
(MANAGER, CAPITAL PROJECTS AND INSPECTIONS)
Representative as Per G.C. 17

Chad Braley, ASCT
(SENIOR MANAGER, DESIGN AND CONSTRUCTION)

Quarry Road Enhancements

Reference No: 74747

Schedule 1

Schedule of Contract Documents

(INCLUDE IN LIST ALL DOCUMENTS INCLUDING, IF ANY, SUPPLEMENTARY GENERAL CONDITIONS, SUPPLEMENTARY SPECIFICATIONS, SUPPLEMENTARY STANDARD DETAIL DRAWINGS)

The following is an exact and complete list of the *Contract Documents*, as referred to in Article 2.1 of the Agreement.

NOTE: The documents noted with "*" are contained in the "Master Municipal Construction Documents – General Conditions, Specifications and Standard Detail Drawings", edition dated 2009. All sections of this publication are included in the *Contract Documents*.

1. Agreement, including all Schedules;
2. The following Addenda:
 - As issued
3. Supplementary General Conditions, if any;
4. General Conditions*;
5. Supplementary Specifications, if any;
6. Detail Specifications, if any;
7. Specifications*;
8. Supplementary Detail Drawings, if any;
9. Standard Detail Drawings*;
10. Executed Form of Tender, including all Appendices;
11. Drawings listed in Schedule 2 to the Agreement – "List of Drawings", if any;
12. Instructions to Tenderers;
13. COQUITLAM "Supplementary Specifications Master Municipal Construction Documents" March 2022

Quarry Road Enhancements

Reference No: 74747

Schedule 2

LIST OF DRAWINGS

(Complete Listing of All Drawings, Plans and Sketches That Are Part of the Contract Documents)

Bound in this Document:

Appendix A: Traffic Management Detail Specifications

Appendix B: Archaeological Chance Find Procedures

Appendix C: Additional Information

Appendix D: Construction Mitigation Plan

Bound Separately: Contract Drawings

TITLE	SHEET NO.	REVISION NO.	DATE
COVER	00	-	-
GENERAL NOTES	01	A	2026-05-27
TYPICAL SECTIONS	02	A	2026-05-27
TYPICAL SECTIONS	03	A	2026-05-27
ROADWORKS	04	A	2026-05-27
ROADWORKS	05	A	2026-05-27
ROADWORKS	06	A	2026-05-27
ROADWORKS	07	A	2026-05-27
ROADWORKS	08	A	2026-05-27
ROADWORKS	09	A	2026-05-27
PAVEMENT MARKING & SIGNAGE	10	A	2026-05-27
PAVEMENT MARKING & SIGNAGE	11	A	2026-05-27
PAVEMENT MARKING & SIGNAGE	12	A	2026-05-27
CROSS SECTIONS	13	A	2026-05-27
CROSS SECTIONS	14	A	2026-05-27
CROSS SECTIONS	15	A	2026-05-27
CROSS SECTIONS	16	A	2026-05-27
CROSS SECTIONS	17	A	2026-05-27
CULVERT KEY PLAN	18	A	2026-05-27
CULVERTS - STCV 18317	19	A	2026-05-27
CULVERTS - STCV 18318	20	A	2026-05-27
CULVERTS - STCV 18327	21	A	2026-05-27

TITLE	SHEET NO.	REVISION NO.	DATE
CULVERTS - STCV 18319	22	A	2026-05-27
CULVERTS - WILDLIFE CROSSING 1	23	A	2026-05-27
CULVERTS - STCV 18388	24	A	2026-05-27
CULVERTS - WILDLIFE CROSSING 2	25	A	2026-05-27
CULVERTS - STCV 18389	26	A	2026-05-27
CULVERTS - STCV 18322	27	A	2026-05-27
CULVERTS - STCV 18390	28	A	2026-05-27
CULVERTS - STCV 18325/18326	29	A	2026-05-27
INLETS & OUTLET DETAILS	30	A	2026-05-27

Supplementary General Conditions

SUPPLEMENTARY GENERAL CONDITIONS

TABLE OF CONTENTS

	Page
Supplementary General Conditions to MMCD Volume II, 2009 Issue	SGC 1 to SGC 18
Section 1: DEFINITIONS	SGC 3
1.1 Abnormal Weather	SGC 3
Section 2: DOCUMENTS	SGC 3
2.2 Interpretation	SGC 3
Section 4: CONTRACTOR	SGC 3 to 7
4.1 Control of Work	SGC 3
4.2 Safety	SGC 4
4.3 Protection of Work, Property and the Public	SGC 4
4.6 Construction Schedule	SGC 5
4.7 Superintendent	SGC 5
4.8 Workers	SGC 5
4.9 Materials	SGC 5
4.11 Subcontractors	SGC 6
4.12 Tests and Inspections	SGC 6
4.14 Final Clean-up	SGC 7
4.16 Notice of Disruption	SGC 7
Section 7: CHANGES	SGC 7 to 8
7.1 Changes	SGC 7
7.4 Optional Work	SGC 7
Section 9: VALUATION OF CHANGES AND EXTRA WORK	SGC 8
9.2 Valuation Method	SGC 8
9.4 Quantity Variations	SGC 8
Section 10: FORCE ACCOUNTS	SGC 8
10.1 Force Account Costs	SGC 8
Section 12: HAZARDOUS MATERIALS	SGC 9
12.2 Discovery of Hazardous Materials	SGC 9
Section 13: DELAYS	SGC 9 to 10
13.1 Delay by Owner or Contract Administrator	SGC 9
13.3 Unavoidable Delay	SGC 9
13.8 Direction to Stop or Delay	SGC 9
13.9 Liquidated Damages for Late Completion	SGC 9
Section 18: PAYMENT	SGC 10 to 11
18.1 Preparation of Payment Certificate	SGC 10

18.4	Holdbacks	SGC 10
18.6	Substantial Performance	SGC 10
Section 19: TAXES, DUTIES AND GST		SGC 11 to 12
19.4	Tariffs or Duties.....	SGC 11
Section 21: WORKERS COMPENSATION REGULATIONS		SGC 12
21.2	Contractor is "Prime Contractor"	SGC 12
Section 24: INSURANCE.....		SGC 12 to 17
24.1	General	SGC 12
24.2	Required Insurance	SGC 13
24.3	Physical Loss or Damage with Respect to New Buildings under Construction and/or Major Additions to Existing Structures	SGC 14
24.4	Additional Insured	SGC 17
Section 25: MAINTENANCE PERIOD		SGC 17
25.1	Correction of Defects	SGC 17
Section 27: CONTRACTOR PERFORMANCE EVALUATION		SGC 18
APPENDICES		SGC 19 to SGC 25
Appendix I	Performance Bond	SGC 19 to 20
Appendix II	Labour and Material Payment Bond	SGC 21 to 23
Appendix III	Certificate of Insurance	SGC 24
Appendix IV	Prime Contractor Designation Letter	SGC 25

1.0 DEFINITIONS

1.1 Abnormal Weather 1.1.1 **(Replace clause 1.1.1 as follows):**
Abnormal Weather” means temperature, precipitation, wind or other weather conditions in which the monthly average, differs from the statistical average for that condition in that period by more than one standard deviation, calculated based on data available from Environment Canada. Coquitlam’s Burke Mountain Rain Gauge will be used to compare the rainfall summary versus the available data from Environment Canada.
[City of Coquitlam Rainfall](#)

2.0 DOCUMENTS

2.2 Interpretation 2.2.4 (1) **(Replace clause 2.2.4 (1) as follows):**
The Contract Documents shall govern and take precedence in the following order as listed in Schedule 1 of the Agreement, taking precedence over all Contract Documents.

4.0 CONTRACTOR

4.1 Control of the Work 4.1.1 **(Add to clause 4.1.1 as follows):**
The *Contractor* is responsible for all survey layout for the construction of the Work to the design specifications and/or elevations as shown on the contract drawings or as amended on site by the Contract Administrator, unless otherwise described in the Contract Document.

4.1.2 **(Add to clause 4.1.2 as follows):**
The Contractor shall not deposit any material upon any street, sidewalk, boulevard or other property, without the Contract Administrator’s or the Owner’s permission, nor shall they allow the same to remain longer than necessary. All surplus spoil and rubbish and other waste material shall be removed from the site so that the area of work is cleaned up and restored to as clean a condition as it was before the Contract started, within four days of the Contract Administrator’s written request to do so, failing which the Owner may carry out the work or have the work carried out by others and recover the costs from the Contractor or may deduct the cost from any monies due or that may become due to the Contractor.

4.1.3 **(Add new clause 4.1.3 as follows):**
Work can be performed during the normal weekday working hours of 0700h to 1900h, unless specified otherwise in Supplementary Specifications - Appendix A:

These Supplementary General Conditions must be read in conjunction with the General Conditions contained in the Master Municipal Construction Documents, Volume II, Printed 2009

Traffic Management Detail Specifications. Written permission from the Contract Administrator will be required for any works to be performed outside of the normal working days of Monday to Friday.

No Sunday work will be permitted, except in case of emergency and then only with the written permission of the Contract Administrator and to such extent as he deems necessary.

In case the Contractor decides to work on a day which is a Statutory Holiday, they shall provide the Contract Administrator in writing at least (4) days in advance of such holiday, stating those places where said work is to be conducted. In case the Contractor fails to give such notice in advance of any Statutory Holiday, no work within the terms of the contract shall be done on such holiday.

The cost of inspections on a Sunday or on a Statutory Holiday by City staff/s will be at Contractor's expense.

4.2 Safety

4.2.2

(Add new clause 4.2.2 as follows):

In an emergency, gas pipeline rupture or leak, Contact FortisBC's 24 Hour Emergency Line (1-800-663-9911) and Coquitlam Fire (911) immediately and then City of Coquitlam's Utility Control Centre (604-927-6287).

4.3 Protection of Work, Property and the Public

4.3.1

(Replace clause 4.3.1 as follows):

In performing the Work, the Contractor shall protect the Work and the Owner's property and other person's property from damage. The Contractor shall at the Contractor's own expense make good any such damage which arises as the result of the Contractor's operations. If the Contractor causes damage to private property, the Contractor must obtain a written release from the owner of the damaged property.

4.3.5.1

(Add clause 4.3.5.1 as follows):

The Contractor shall notify the Contract Administrator immediately if damage occurs to any City or third party utility or structure.

4.3.7

(Add new clause 4.3.7 as follows):

Any lands other than those upon which the work is to be performed, which may be required for temporary facilities, storage purposes or access to the work site, other than those provided by the *Owner*, shall be provided by the *Contractor* at their own cost, with no liability to the *Owner*.

- | | | | |
|------------|------------------------------|-------|---|
| 4.6 | Construction Schedule | 4.6.1 | <i>(Replace clause 4.6.1 as follows):</i>
The Contractor shall within the time set out in the Form of Tender prepare and submit to the Contract Administrator for their approval a construction schedule (the Baseline Construction Schedule) indicating the planned start and completion dates of major activities of the Work. The Baseline Construction Schedule shall be in more detail than the Preliminary Construction Schedule and shall indicate completion of the Work in compliance with any specified Milestone Dates, including Substantial Performance. |
| | | 4.6.6 | <i>(Replace clause 4.6.6 as follows):</i>
The time for the performance of the Work shall commence on the date specified in the Notice to Proceed, or if not so specified, on the date the Notice to Proceed is issued. The Notice to Proceed will not be issued until the documentation required under paragraph 5.1.1 of the Form of Tender has been submitted and the construction schedule has been approved. |
| | | 4.6.8 | <i>(Add new clause 4.6.8 as follows):</i>
Any requests to lengthen the work schedule shall be made in writing by the Contractor within five working days of knowledge of the reason for the extension. The Contract Administrator will adjust the schedule at their discretion upon receipt of a written request. |
| 4.7 | Superintendent | 4.7.4 | <i>(Add new clause 4.7.4 as follows):</i>
The key personnel named in the Contractor's Tender response, shall remain in these key positions throughout the project. In the event that key personnel leave the Contractor's firm, or for any unknown reason are unable to continue fulfilling their role, the Contractor must propose a suitable replacement, and obtain written consent from the Owner. Acceptance of the proposed replacement is at the sole discretion of the Contract Administrator and the Owner. |
| 4.8 | Workers | 4.8.2 | <i>(Add new clause 4.8.2 as follows):</i>
The Contractor shall, upon the request of the Contract Administrator, remove any person employed by them for the purposes of the Contract who, in the opinion of the Contract Administrator, is incompetent or has conducted themselves improperly, and the Contractor shall not permit a person who has been removed to return to the Place of Work. |
| 4.9 | Materials | 4.9.3 | <i>(Add new clause 4.9.3 as follows):</i>
The Contractor shall, at their cost, |

These Supplementary General Conditions must be read in conjunction with the General Conditions contained in the Master Municipal Construction Documents, Volume II, Printed 2009

- a) Be responsible for storing all of the materials supplied for the Work either by themselves or the Owner, until it has been incorporated into the completed Work;
- b) Store all materials in a manner which will prevent damage from the weather, dirt, foreign matter, vandalism and theft;
- c) Arrange for and/or verify the time of delivery of all materials to be supplied by themselves or the Owner to ensure that delivery will coincide with their work schedules.
- d) Examine with the Contract Administrator the quantities and details of all materials supplied by the Owner at the time and place of delivery or those materials already at the Place of Work, and prepare and sign a Statement of Materials Acceptance, specifically noting and rejecting any defective material;
- e) Replace all materials supplied by themselves or the Owner which are found to be stolen, missing or damaged while under their care;
- f) Replace all materials found to be defective in manufacture which have been supplied by themselves.

4.11 Subcontractors 4.11.3

(Replace clause 4.11.3 as follows):

The Contractor shall, upon notice of the Contract Administrator, remove any Subcontractor employed by them for the purposes of the Contract who, in the opinion of the Contract Administrator, is incompetent or has conducted themselves improperly, and the Contractor shall not permit the Subcontractor who has been removed to return to the Place of Work. The removal of a Subcontractor under this clause shall not be considered a Change and the Contract Price and the Contract Time shall not be adjusted.

4.12 Test and Inspections 4.12.1

(Replace clause 4.12.1 as follows):

The Contractor shall perform or cause to be performed all tests, inspections and approvals of the Work as described in the Contract Documents or as required by the Contract Administrator as part of Quality Control. The Contractor shall complete all the necessary testing at the frequencies described in the Contract Document unless otherwise approved by the Contract Administrator.

Acceptable test and inspection results will not relieve the Contractor of its obligations under the Contract to correct defects or deficiencies in the Work.

4.12.11 ***(Add clause 4.12.11 as follows):***

Failure to follow DFO/FLNRO BMPs and the approved permit for Instream Works or as instructed by Contract Administrator will result in shut-down of the work. The

These Supplementary General Conditions must be read in conjunction with the General Conditions contained in the Master Municipal Construction Documents, Volume II, Printed 2009

Contractor must take all steps to mitigate impacts to aquatic resources, environment and habitats before work can re-start on site. No claim will be accepted by the Owner for costs associated with this work shut-down.

4.14 Final Clean-up

4.14.1

(Replace clause 4.14.1 as follows):

Prior to applying for Substantial Performance, the Contractor shall remove all surplus products, tools, construction machinery and equipment relating to the Work that is not required for the performance of the remaining Work. The Contractor shall also remove waste, debris and waste products other than caused by the Owner or Other Contractors, and leave the Place of Work clean and suitable for occupancy by the Owner unless otherwise specified in the Contract Documents or directed by the Contract Administrator.

4.16 Notice of Disruption

4.16.2

(Add new clause 4.16.2 as follows):

Written notice must be provided to all properties which may be physically affected by the construction not less than one week and not more than two weeks prior to construction.

Notify occupants directly affected by the work 48 hours in advance of commencement of construction. Cost of notifying area occupants of ensuing construction and delivery of the notices is incidental to the Contract.

7.0 CHANGES

7.1 Changes

7.1.3

(Replace clause 7.1.3 as follows):

Additional work that the Owner may wished performed that does not satisfy the requirements of subparagraphs (a) and (b) of GC 7.1.1 is extra work (Extra Work) and is not a Change. Pursuant to GC 8, Extra Work may be declined by the Contractor or may, upon agreement between the parties, be undertaken as Extra Work.

7.4 Optional Work

7.4.2

(Add new clause 7.4.2 as follows):

If there are Optional items or Provisional items included in the *Schedule of Quantities and Prices*, those items shall be used only as directed and at the sole discretion of the Contract Administrator through the issue of a Change Order. These items will be paid at the contract unit price as part of regular progress payments. Only quantities used will be eligible for payment. No claim will be accepted for unused Optional or Provisional quantities. Clause 9.4 Quantity Variations will not be applicable for these items.

9.0 VALUATION OF CHANGES AND EXTRA WORK

9.2 Valuation Method

9.2.4

(Replace clause 9.2.4 as follows):

Once a quotation is accepted by the Contract Administrator, or other agreement reached between the Contract Administrator and the Contractor regarding adjustments to the Contract Price or Contract Time on account of a Change or Extra Work, the Contractor shall not be entitled to claim or receive additional payment, or adjustment to the Contract Time on account of a Change or Extra Work.

9.4 Quantity Variations

9.4.1

(Replace clause 9.4.1 as follows):

If for any reason, including an addition or deletion under GC 7.1.1(1) or 7.1.1(2) respectively, the actual quantity of a unit price item varies by more than plus or minus the Variance Threshold Percentage from the estimated quantity for that unit price item listed in the Schedule of Quantities and Prices (the "Tender Quantity") or as otherwise agreed to pursuant to these Contract Documents, then either the Owner or the Contractor may by written notice request the other party to agree to a revised unit price, considering the change in quantities. A party shall make a request for a revised unit price as soon as reasonably possible after the party concerned becomes aware of the quantity variation.

9.4.2

(Delete clause 9.4.2 (2))

10.0 FORCE ACCOUNTS

10.1 Force Account Costs

10.1.1(1)

(Add to clause 10.1.1(1) as follows):

Costs for the Contractor's Superintendent, Project Managers, Health and Safety Personnel, and Office/Administration Staff are not eligible for labour costs as those costs are considered incidental to the mark up owing for overhead and labour.

10.1.1(4)

(Replace clause 10.1.1(4) as follows):

Force Account Work performed by a subcontractor shall be paid for in the lesser of: (i) the amount provided by subparagraphs (1), (2) and (3) of this GC, plus a mark-up of 5%, or (ii) the actual amount the Contractor pays the subcontractor including a mark-up of 10% on such actual costs to cover all overhead and profit.

12.0 HAZARDOUS MATERIALS

12.2 Discovery of Hazardous Materials

12.2.2

(Replace clause 12.2.2 as follows):

If the Contract Administrator observes any materials at the Place of Work that the Contract Administrator knows or suspects may be Hazardous Materials, then the Contract Administrator shall immediately give written notice to the Contractor and the Contractor shall immediately stop the Work or portion of the Work as required by GC 12.2.1(1).

13.0 DELAYS

13.1 Delay by Owner or Contract Administrator

13.1.2

(Add new clause 13.1.2 as follows):

The Owner may at any time suspend the work or any portion thereof provided they give the Contractor five (5) days' written notice of delay. The Contractor shall resume work upon written notice from the Owner. The Contractor shall be entitled to:

- a) An extension of the Contract time equivalent to the length of suspension of work.
- b) Reimbursement by the Owner for directly related out-of-pocket additional costs, reasonably and necessarily incurred by the Contractor as a result of such suspension. No additional payment will be made to the Contractor for any loss of profits or overhead.

13.3 Unavoidable Delay

13.3.1

(Add to clause 13.3.1 as follows):

Beyond the reasonable control of the Contractor also includes pandemic or community outbreak

13.8 Direction to Stop or Delay

13.8.3

(Add new clause 13.8.3 as follows):

The Contract Administrator may order the Contractor to stop work if at any time the Contract Administrator is of the opinion that there exists a danger to life or property.

13.9 Liquidated Damages for Late Completion

13.9.1

(Replace clause 13.9.1 as follows):

If the Contractor fails to meet the Milestone Date for Substantial Performance as set out in the Form of Tender, paragraph 2.2 as may be adjusted pursuant to the provisions of the Contract Documents, then the Owner may deduct from any monies owing to the Contractor for the Work:

- (1) An amount of \$1,000.00 for each calendar day the actual *Substantial Performance* is achieved after the Substantial Performance Milestone Date; plus

- (2) All direct out of pocket costs, such as costs for safety, security or equipment rental, reasonably incurred by the Owner as a direct result of such delay.

If the monies owing to the Contractor are less than the total amount owing by the Contractor to the Owner under (1) and (2) then any shortfall shall immediately, upon written notice from the Owner, and upon Substantial Performance, be due and owing by the Contractor to the Owner.

18.0 PAYMENT

18.1 Preparation of Payment Certificate

18.1.1

(Replace clause 18.1.1 as follows):

The Contract Administrator shall prepare and issue a certificate for the period ending the last calendar day of the month.

18.4 Holdbacks

18.4.2

(Add to clause 18.4.2 as follows):

At the sole discretion of the Contract Administrator, an amount equivalent to 10% of the contract award value or 200% of a reasonable estimate, whichever is higher, may be held without interest until all deficiencies have been remedied and accepted by the Contract Administrator.

18.6 Substantial Performance

18.6.5

(Replace clause 18.6.5 as follows):

The Owner may release any builders lien holdback on the 56th day following the date of Substantial Performance, or other date as required by law, but the Owner may hold back the amounts for any deficiencies or filed builders liens as provided in GC 18.4.2, 18.4.3 and 18.4.4.

18.6.6

(Replace clause 18.6.6 as follows):

The *Contract Administrator*, as defined herein, shall be the *Payment Certifier* responsible under Section 7 of the *Builders Lien Act* for certifying *Substantial Performance* of the *Work* of the *Contractor*, but not the *Work* of *Subcontractors*. The *Contractor* shall cooperate with and assist the *Contract Administrator* by providing information and assistance in a timely manner as the *Contract Administrator* considers necessary to carry out the duties of the *Payment Certifier* for the *Contract*.

The *Contractor* shall be the *Payment Certifier* responsible under Section 7 of the *Builders Lien Act* for certifying *Substantial Performance* of the *Work* of each *Subcontractor*. Prior to certifying completion for a *Subcontractor*, the *Contractor* shall consult the *Contract Administrator* and obtain the *Contract Administrator's* comments on the status of completion by the *Subcontractor*, including any

These Supplementary General Conditions must be read in conjunction with the General Conditions contained in the Master Municipal Construction Documents, Volume II, Printed 2009

deficiencies or defects in the *Subcontractor's Work* noted by the *Contract Administrator*. The *Contractor* will indemnify and save the *Owner* harmless from any and all liability the *Owner* may have to anyone arising out of the certification by the *Contractor* of *Substantial Performance* for that *Subcontractor*.

Notwithstanding any other provision of the *Contract*, no payments will be due or owing to the *Contractor* so long as a Lien filed by anyone claiming under or through the *Contractor* remains registered against the Project of any lands, or interest therein, on which *Work* for the project was performed. Failure of the *Contractor* to remove all Liens promptly will entitle the *Owner* to damages.

**19.0 TAXES, DUTIES AND
GST**

19.4 Tariffs or Duties

19.4.1

Tariffs or Duties refer to taxes, levies, or charges imposed by any level of government (including foreign governments) on imported or domestic goods, materials, or equipment used in the performance of the Work. The Contract Price is based on the tariffs and duties in effect as of the date of the Tender Closing. If, after the Tender Closing Date, any new Tariffs or Duties are imposed, or existing rates are materially increased, and such changes directly and demonstrably affect the cost of materials or equipment required for the performance of the Work, the Contractor shall notify the Contract Administrator in writing within ten (10) Working Days of becoming aware of such change, providing supporting documentation, including but not limited to:

- (1) Affected materials
- (2) Quantity and cost impact
- (3) Evidence of original and new tariff rates
- (4) Reasonable efforts made to mitigate the cost impact (e.g., sourcing alternatives)

19.4.2

If the Contract Administrator is satisfied that the Contractor has incurred additional direct costs solely due to the change in Tariffs or Duties, the Owner will issue a Change Order to adjust the Contract Price accordingly. No adjustment shall be made for Tariffs or Duties that were publicly announced or reasonably foreseeable before the Tender Closing Date.

19.4.3

This clause does not apply to costs incurred due to delays caused by the Contractor's procurement or supply chain management. It also does not apply if the Contractor fails

These Supplementary General Conditions must be read in conjunction with the General Conditions contained in the Master Municipal Construction Documents, Volume II, Printed 2009

to take reasonable steps to mitigate the impact of the change.

- 19.4.4 If the imposition of new Tariffs or Duties causes unavoidable delays in material delivery, the Contractor may request an extension of the Contract Time under GC 13.3, subject to approval by the Contract Administrator.

**21.0 WORKERS
COMPENSATION
REGULATIONS**

**21.2 Contractor is
"Prime Contractor"**

- 21.2.1 ***(Add to clause 21.2.1 as follows):***
Prior to the issuance of the "Notice to Proceed" the Contractor must provide a signed "Prime Contractor Designation" form as provided in Appendix IV of these Supplementary General Conditions.

24.0 INSURANCE

(Replace section 24.0 as follows):

24.1 General

- 24.1.1 **Importance of Prompt Attention to Insurance Requirements:**
The Contractor shall provide the Owner with satisfactory evidence that the insurance required to be provided under this GC is in full force and effect.

- 24.1.2 **Acceptable Insurance Carriers:**
The insurer issuing any policy, or other document which is evidence of insurance to the Contractor, shall be an insurer licensed by the Superintendent of Insurance in the Province of British Columbia and registered with the Department of Insurance for Canada in Ottawa, except the Insurance Corporation of British Columbia, which is not subject to this condition.

- 24.1.3 **Owner's Right to Change Terms:**
Notwithstanding anything contained in the Contract Documents, the Owner will have the right to request a change to the specified terms and conditions respecting insurance at the sole option of the Owner. The Contractor will be notified in writing of any changes required by the Owner and will provide a quotation for such work.

- 24.1.4 **Delivery of Insurance Documents:**
All insurance policies or other acceptable specified documents shall be delivered to, and accepted by, the Owner before the Contract Documents are signed. No work shall be commenced by the Contractor or by anyone acting

These Supplementary General Conditions must be read in conjunction with the General Conditions contained in the Master Municipal Construction Documents, Volume II, Printed 2009

on the instructions of the Contractor, until the required Insurance Documents have been accepted by the Owner and the Contract Documents have been duly signed by the Owner and the Contractor.

24.1.5 **Owner's Right to Insure:**

Should the Contractor for any reason not comply with the specified requirements with respect to the insurance, the Owner will, at the Owner's option, have the right to purchase all or any part of such insurance which, in the opinion of the Owner, may be required to provide the specified insurance, and, in the event of so doing, the Owner will have the right to pay the premiums for such insurance and to withhold the amount of premiums so paid from any amount due and payable to the Contractor under the Contract.

24.2 Required Insurance

24.2.1 **General**

Damage to work (excluding Building Contracts where Section 24.3, Paragraph 24.3.1, Further Responsibilities of Contractor, applies).

The Contractor shall be responsible for any and all loss, or damage, whatsoever which may occur on or to the works, completed or otherwise, until such time as the entire works have been completed and the Notice of Acceptance has been issued by the Owner, except that loss or damage caused solely by an act of the Owner. In the event of any loss or damage occurring, the Contractor shall, on notice from the Contract Administrator, immediately put the works into the condition it was immediately prior to such loss or damage, all at the

Contractor's expense, except where such loss or damage was caused solely by an act of the Owner.

The Contractor shall be responsible for any and all loss or damage whatsoever which may occur on or to the works, completed or otherwise, arising out of the negligence of the Contractor, any subcontractors, and the employees or agents of any of them.

24.2.2 **Public Liability Insurance:**

(Other than Automobile Third Party Liability Insurance):

Evidence of Insurance:

The Contractor shall deposit with the Owner, before the work commences, a Certificate of Insurance, signed by an

authorized representative of the insurer, such certificate to be as shown in Appendix III.

Effective Dates and Terms:

The effective date of the Certificate of Insurance shall be the date of the execution of the Contract Agreement and the term of this policy shall be from such effective date until a date not less than twelve (12) months after the date of Substantial Performance completion of all work under the Contract.

Limits of Liability:

For bodily injury and for property damage shall be inclusive limits not less than \$5,000,000.

24.2.3 **Public Liability Insurance (Automobile):**

The Contractor shall deposit with the Owner before the work commences a Certificate of Insurance with respect to owned automobiles on ICBC Form No. APV 47 entitled "Confirmation of Insurance Coverage" and with respect to Non-Owned Automobiles including hired automobiles and Contractual Liability on ICBC non-owned automobile policy Form APV 29 (if non-owned automobile coverage is not included under the comprehensive general liability coverage) each signed by an authorized representative of the Insurance Corporation of British Columbia.

24.3 Physical Loss or Damage With Respect to New Buildings under Construction and/or Major Additions to Existing Structures

24.3.1 **Responsibility for Placing Insurance:**

The types of insurance required under this section will be provided and maintained at the expense of the City of Coquitlam during the term of the Contract and will be as follows unless otherwise changed by specific endorsement to these Insurance Specifications.

24.3.2 **Insurance Coverage Required:**

Builders Risk Completed Value "All Risks" Course of Construction Insurance. This policy will be written in the names of the City of Coquitlam and the Contractor with loss payable as their respective interests may appear.

24.3.3 **Responsibility of Contractor - Limitations of cover and deductibles:**

The insurance provided by the City of Coquitlam as described herein will not provide the Contractor with full protection against any and all kinds of loss or damage which may arise out of the Contract. It is, therefore, the responsibility of the Contractor to fully understand the scope of the cover provided with particular attention to the

exclusions, limitations of cover and deductible provisions contained in the Insuring Agreements of the policies and it is further the responsibility of the Contractor to take out at the Contractor's expense, whatever other additional insurance the Contractor may consider necessary or desirable for his protection subject as hereinafter provided. The Contractor shall act in the same manner on insurance made available through the City of Coquitlam as he would if he had arranged such insurance himself.

24.3.4 **Responsibility of Contractor - Direct Damage Insurance:**

If the Contractor fails to do all or anything that is required of them concerning insurance, the City of Coquitlam may do what is required and any monies expended by the City of Coquitlam for that purpose shall be repayable and recoverable from the Contractor. Should any action, failure or negligence of the Contractor result in higher insurance costs being incurred by the City of Coquitlam, such additional costs shall be payable or recoverable from the Contractor.

24.3.5 **Responsibility of Contractor - Machinery and Equipment Belonging to Others:**

Unless otherwise directed by the City of Coquitlam in writing, the Contractor shall carry insurance covering loss or damage to construction machinery, tools and equipment owned by and/or on bare rental from a third party or parties and used by the Contractor in performing the work, which insurance shall be in a form satisfactory to the City of Coquitlam and having coverage in accordance with the actual cash value of such construction machinery, tools and equipment. Such policies shall also provide for subrogation to be waived against the City of Coquitlam. A certified copy of the policy shall be delivered to the City of Coquitlam not later than thirty days after the commencement of work under the Contract.

24.3.6 **Contractor's Waiver of Liability to Coquitlam:**

The Contractor hereby releases the City of Coquitlam from any and all liability for damages to the extent that such damages are covered by the course of construction insurance referred to in Section 24.3 of these specifications.

24.3.7 **Liability of Contractor:**

Neither the providing of insurance by the Contractor or the City of Coquitlam in accordance with the requirements hereof, nor the insolvency, bankruptcy, nor failure of any insurance company to pay any claim accruing shall be held

to waive any of the provisions of this Contract with respect to the liability of the Contractor or otherwise.

24.3.8 **Responsibility of Contractor for protection of work, persons and property:**

The Contractor and all persons employed by the Contractor or under their control, and all employees and subcontractors, shall use due care that no person or property is injured, and that no rights are infringed in the prosecution of the work. Contractors shall take particular care to protect the work against loss or damage caused by riot, vandalism or malicious mischief and shall be at the expense of the Contractor provide all necessary safeguards in the form of watchmen and/or watch dog protection to prevent loss or damage of this type. The payment of deductibles is the responsibility of the Contractor and if not paid by the Contractor such amounts shall be deducted by the City of Coquitlam from payment due to the Contractor. These deductibles will normally be \$250.00 each claim.

24.3.9 **Action to be taken in the event of loss or damage to the work covered by the Contract:**

When any loss or damage occurs to the work or to any materials and supplies on the site of the work, the Contractor shall remove any and all damaged or destroyed property and shall rebuild or replace the damaged or destroyed work, materials, or supplies and complete the work to the satisfaction of the Owner. For such removal, rebuilding, or replacing, the Contractor shall be entitled to receive from the Owner the amount of insurance monies received by the Owner pursuant to the said adjustment which amount shall be paid to the Contractor as the work of rebuilding or replacing proceeds, and in accordance with the Agreement. Damage or destruction of the whole or any part of the work shall not affect the rights and obligations of either party under the Agreement, except that in such event the Contractor shall be entitled to such reasonable extension of time to complete the work as the Architect and/or Contract Administrator may decide.

24.3.10 **Further responsibility of Contractor:**

Other than with respect to loss or damage arising out of insured risks and herein before specified, the Contractor shall be responsible for all loss or damage whatsoever which may occur on or to the works completed or otherwise, until such time as the entire works have been completed and the Notice of Acceptance has been issued by the Owner, except that loss or damage caused solely by an act of the Owner.

In the event of any loss or damage occurring, the Contractor shall on notice from the Owner immediately put the works into the condition it was immediately prior to such loss or damage, all at the Contractor's expense except as previously stated.

24.3.11 **Owner Not Responsible for Loss or Damage or Loss of Use of Property of Contractors and their Employees:**

The Owner will not be responsible for securing or paying for insurance of any kind other than as specified in Section 24.3 of these specifications nor will the Owner have any responsibility whatsoever for loss or damage from whatever cause occurring to property owned, leased, or otherwise in the possession of the Contractor, subcontractors or their employees including, without restricting the generality of the foregoing, machinery, equipment, tools, supplies, and clothing at the construction site or elsewhere including loss of use of same.

24.4 Additional Insured 24.4.1

The Contractor shall ensure the following are named as "additional insured" on the liability policy for this contract:

- The City of Coquitlam

The City may identify private properties that are directly affected by construction. If so, the Contractor shall include the legal owners of these properties named as "additional insured" on the liability policy for this contract.

25.0 MAINTENANCE PERIOD

25.1 Correction of Defects 25.1.4

(Add new clause 25.1.4 as follows):

The Owner is authorized to make repairs to defects or deficiencies if, ten days after giving written notice, the Contractor has failed to make or undertake with due diligence the required repairs. However, in the case of emergency where, in the opinion of the Owner, delay is not reasonable, repairs may be made without notice being sent to the Contractor. All expenses incurred by the Owner in connection with repairs made pursuant to GC 25 shall be paid by the Contractor or may be deducted from the Maintenance Security, or other holdbacks. The Contractor shall promptly pay any shortfall.

**27.0 CONTRACTOR
PERFORMANCE
EVALUATION**

27.1

(Add new clause 27.1 as follows):

After the completion of the Contract, the Contractor will be evaluated on their performance of the Work. The evaluation will provide percentage scores on the following categories:

1. *Contract Administration*
2. *Construction Management*
3. *Schedule Management*
4. *Communications*
5. *Resource Management and Contractor Performance*
6. *Quality Management*

An evaluation summary report may be issued to the Contractor with scores for each of these categories. Upon request, the Contractor may attend a meeting with the City to discuss the evaluation.

This internal evaluation may be reviewed for reference on subsequent tenders with the City. Evaluation scores can form part of the tender analysis and influence contract award decisions.

Evaluation Scores in categories that are below 50% may result in a suspension of tendering privileges with the City.

APPENDIX I

PERFORMANCE BOND

NO. _____ \$ _____

KNOW ALL MEN BY THESE PRESENTS THAT

As Principal, hereinafter called the Principal, and

As Surety, hereinafter called the Surety, are held and firmly bound unto

As Obligee, hereinafter called the Obligee, in the amount of

_____ Dollars
(\$ _____)

lawful money of Canada, for the payment of which sum, well and truly to be made, the Principal and the Surety bind themselves, their heirs, executors, administrators, successors and assigns, jointly and severally, firmly by these presents.

WHEREAS, the Principal has entered into a written contract with the Obligee, dated the _____ day of _____ 20____, for

in accordance with the drawings and specifications submitted, therefore, which contract, drawings and specifications and addenda thereto, to the extent provided for, are by reference made part hereof and are hereinafter referred to as the Contract.

NOW THEREFORE, THE CONDITION OF THIS OBLIGATION is such that, if the Principal shall promptly and faithfully perform said Contract (including any addenda thereto, provided such addenda do not collectively increase the amount to be paid to the Principal by more than twenty per cent (20%) of the amount of the Contract except with the written consent of the Surety) then this obligation shall be null and void; otherwise, it shall remain in full force and effect.

These Supplementary General Conditions must be read in conjunction with the General Conditions contained in the Master Municipal Construction Documents, Volume II, Printed 2009

Whenever the Principal shall be, and declared by Obligee to be, in default under the Contract, the Obligee having performed Obligee's obligations thereunder, the Surety may promptly remedy the default, or shall promptly:

1. Complete the Contract in accordance with its terms and conditions, or
2. Obtain a bid or bids for submission to Obligee for completing the Contract in accordance with its terms and conditions, and upon determination by Obligee and Surety of the lowest responsible bidder, arrange for a contract between such bidder and Obligee and make available as work progresses (even though there should be a default or a succession of defaults under the contract or contracts of completion arranged under this paragraph) sufficient funds to pay the cost of completion less the balance of the contract price; but not exceeding, including other costs and damages for which the Surety may be liable hereunder, the amount set forth in the first paragraph hereof. The term 'balance of the contract price', as used in this paragraph, shall mean the total amount payable by Obligee to Principal under the Contract less the amount properly paid by Obligee to Principal.

Any suit under this Bond must be instituted before the expiration of two (2) years from date on which the Notice of Acceptance under the Contract is issued.

The Surety shall not be liable for a greater sum than the specified penalty of this Bond.

No right of action shall accrue on this Bond to or for the use of any person or corporation other than the Obligee named herein or the heirs, executors, administrators, or successors of Obligee.

IN TESTIMONY WHEREOF, the Principal has hereto set its hand and affixed its seal, and the Surety has caused these presents to be sealed with its corporate seal duly attested by the signature of its Attorney-in-fact, this ____ day of _____ 20 ____.

SIGNED, SEALED and DELIVERED

In the presence of

)
)
)
)
)

PRINCIPAL

SURETY

APPENDIX II

LABOUR AND MATERIAL PAYMENT BOND

(Private Contracts – Trustee Form)

NO. _____

\$ _____

Note: This Bond is issued simultaneously with another Bond in favour of the Obligee conditioned for the full and faithful performance of the Contract.

KNOW ALL MEN BY THESE PRESENTS THAT

As Principal, hereinafter called the Principal, and

As Surety, hereinafter called the Surety, are, subject to the conditions hereinafter contained, held and firmly bound unto

As Trustee, hereinafter called the Obligee, for the use and benefit of the Claimants, their and each of their heirs, executors, administrators, successors and assigns in the amount of

_____ Dollars
(\$ _____) lawful money of Canada, for the payment of which sum well and truly to be made, the Principal and the Surety bind themselves, their heirs, executors, administrators, successors and assigns jointly and severally, firmly by these presents.

SIGNED AND SEALED this _____ day of _____, 20____.

WHEREAS, the Principal has entered into a written contract with the Obligee dated the _____ day of _____, 20____, for

which contract is by reference made a part hereof, and is hereinafter referred to as the Contract.

NOW, THEREFORE, THE CONDITION OF THIS OBLIGATION is such that, if the Principal shall make payment to all Claimants for all labour and material used or reasonably required for use in the performance of the Contract, then this obligation shall be null and void; otherwise it shall remain in full force and effect, subject, however, to the following conditions:

These Supplementary General Conditions must be read in conjunction with the General Conditions contained in the Master Municipal Construction Documents, Volume II, Printed 2009

1. A Claimant for the purpose of this Bond, is defined as one having a direct contract with the Principal for labour, material, or both, used or reasonably required for use in the performance of the Contract, labour and material being construed to include the part of water, gas, power, light, heat, oil, gasoline, telephone service or rental equipment directly applicable to the Contract provided that a person, firm or corporation who rents equipment to the Principal to be used in the performance of the Contract under a contract which provides that all or any part of the rent is to be applied towards the purchase price thereof shall only be a Claimant to the extent of the prevailing industrial rental value of such equipment for the period during which the equipment was used in the performance of the Contract. The prevailing industrial rental value of equipment shall be determined, insofar as it is practical to do so, in accordance with and in the manner provided for in the latest revised edition of the publication of the Canadian Construction Association entitled "Rental Rates on Contractors' Equipment" published prior to the period during which the equipment was used in the performance of the Contract.
2. The Principal and the Surety hereby jointly and severally agree with the Oblige as Trustee that every Claimant who has not been paid as provided for under the terms of his contract with the Principal before the expiration of a period of ninety (90) days after the date on which the last of such Claimant's work or labour was done or performed or materials were furnished by such Claimant, may as a beneficiary of the trust herein provided for, sue on this Bond, prosecute the suite to final judgment for such sum or sums as may be justly due to such Claimant under the terms of his said contract with the Principal and have execution thereon. Provided that the Oblige is not obliged to do or take any act, action or proceeding against the Surety on behalf of the Claimants or any of them to enforce the provisions of this Bond. If any act, action or proceeding is taken either in the name of the Oblige or by joining the Oblige as a party to such proceedings then such act, action or proceeding shall be taken on the understanding and basis that the Claimants or any of them who take such act, action or proceeding shall indemnify and save harmless the Oblige against all costs, charges and expense or liabilities incurred thereon and any loss or damage resulting to the Oblige by reasons thereof. Provided still further that subject to the foregoing terms and conditions, the Claimants or any of them may use the name of the Oblige to sue on and enforce the provisions of this Bond.
3. No suit or action shall be commenced hereunder by any Claimant:
 - a) unless such Claimant shall have given written notice within the time limits hereinafter set forth to each of the Principal, Surety and Oblige, stating with substantial accuracy the amount claimed. Such notice shall be served by mailing the same by registered mail to the Principal, Surety and Oblige at any place where an office is regularly maintained for the transaction of business by such persons or served in any manner in which legal process may be served in the Province or other part of Canada in which the subject matter of the contract is located. Such notice shall be given (i) in respect of any claim for the amount or any portion thereof required to be held back from the Claimant by the Principal under either the terms of the Claimant's contract with the Principal or under the Mechanic's Liens Legislation applicable to the Claimant's contract with the Principal whichever is the greater within one hundred and twenty (120) days after such Claimant should have been paid in full under the Claimant's contract with the Principal; (ii) in respect of any claim other than for the holdback or portion thereof referred to above within one hundred and twenty (120) days after the date upon which such claimant did

or performed the last of the work or labour or furnished the last of the materials for which such claim is made under the Claimant's contract with the Principal.

- b) after the expiration of one (1) year following the date on which Principal ceased work on the Contract including work performed under guarantees provided in the Contract.
- c) Other than in a court of competent jurisdiction in the Province or District of Canada in which the subject matter of the Contract or any part thereof is situated and none elsewhere, and the parties hereto agree to submit to the jurisdiction of such court.

4. The amount of this Bond shall be reduced by and to the extent of any payments made in good further and in accordance with the provisions which may be filed of record against the subject matter of the Contract, whether or not claim for the amount of such lien be presented under and against this Bond.

5. The Surety shall not be liable for a greater sum than the specified penalty of this Bond.

IN TESTIMONY WHEREOF, the Principal has hereto set its hand and affixed its seal, and the Surety has caused these presents to be sealed with its corporate seal duly attested by the signature of its Attorney-in-fact the day and year first above written.

SIGNED, SEALED and DELIVERED

In the presence of

)
)
)
)
)

PRINCIPAL

SURETY

APPENDIX III

CERTIFICATE OF INSURANCE

This Certificate issued to the City of Coquitlam is to certify that policies of insurance, as described below, have been issued to the Insured named below and are in force at this time. It is understood and agreed that thirty (30) days' prior written notice by registered mail of any material alterations, transfer, assignment or cancellation of any of the policies listed below, either in part or in whole, will be given to the holder of this Certificate.

A. This Certificate is issued to: Named Insured and Mailing Address:

City of Coquitlam
3000 Guildford Way
Coquitlam, BC V3B 7N2

B. CONTRACT NUMBER AND/OR NAME Description of the Work:

C. INSURANCE POLICY

Name of Insurer:
Policy Number:
Effective Date:

Liability Limit:
Expiry Date:

D. INSURANCE COVERAGE

COMMERCIAL GENERAL LIABILITY coverage is required to insure against liability from the activities arising out of operations or work in connection with the above-described project, including liability arising out of the use of City property.

- D.1 The minimum limit shall be \$5,000,000.00 inclusive per occurrence against bodily injury, personal injury and property damage.
- D.2 The City of Coquitlam, its employees, officers, agents and volunteers are added as Additional Insureds, but only with respect to operations conducted by or on behalf of the Named Insured in connection with the above-described project, operations or work.
- D.3 This insurance shall be primary as regards the City of Coquitlam, its employees, officers, agents and volunteers as Additional Insureds.
- D.4 Any deductible or reimbursement clause contained in the policy shall not apply to the City of Coquitlam and shall be the sole responsibility of the Named Insured.
- D.5 The insurance shall include the following coverages:
 - D.5.1 Cross Liability Clause
 - D.5.2 Non-Owned Automobile Liability
 - D.5.3 Unlicensed Automobile Liability
 - D.5.4 Blanket Contractual Liability
 - D.5.5 Broad Form Property Damage Liability
 - D.5.6 Owner's & Contractor's Protective Liability
 - D.5.7 Products & Completed Operations Liability

D.6 Indicate provision of special coverage for this project as required by the City:

YES	NO	Special Coverage Description
-----	----	------------------------------

- | | | |
|--------------------------|-------------------------------------|---------------------------------|
| <input type="checkbox"/> | <input checked="" type="checkbox"/> | Shoring and Underpinning Hazard |
| <input type="checkbox"/> | <input checked="" type="checkbox"/> | Pile Driving and Vibrations |
| <input type="checkbox"/> | <input checked="" type="checkbox"/> | Excavation Hazard |
| <input type="checkbox"/> | <input checked="" type="checkbox"/> | Demolition |
| <input type="checkbox"/> | <input checked="" type="checkbox"/> | Blasting |

Authorized Signature and Stamp

Date Name and Title

City' broker to return to City Representative Department

These Supplementary General Conditions must be read in conjunction with the General Conditions contained in the Master Municipal Construction Documents, Volume II, Printed 2009



APPENDIX IV

PRIME CONTRACTOR DESIGNATION

Owner: **City of Coquitlam**
Contractor: _____
Contract / Permit #: **74747**
Project / Workplace: **Quarry Road Enhancements** (the "Project")

By signing this Prime Contractor Designation form, the Contractor hereby:

1. agrees to be, and accepts designation as, the "prime contractor" for the purposes of the Workers Compensation Act, R.S.B.C. 2019, c. 1 (the "Act") and the Occupational Health and Safety Regulation, B.C. Reg. 223/2022 (the "Regulation") in respect of the Project and Workplace noted above;
2. represents and warrants that the Contractor is qualified and capable to perform the duties of prime contractor and that the undersigned signatory has the authority to accept designation as prime contractor and to bind the Contractor;
3. accepts the duty and responsibility for ensuring the activities of employers, workers and other persons at the Workplace relating to occupational health and safety are coordinated and agrees to do everything that is reasonably practicable to establish and maintain a system or process that will ensure compliance with the Act and the Regulation in respect of the Workplace;
4. covenants and agrees to comply with the occupational health and safety provisions of the Act, the Regulation, any other applicable regulations under the Act, and any applicable orders;
5. acknowledges and agrees that the Owner has provided the Contractor the information known to the Owner that is necessary to identify and eliminate or control hazards to the health or safety of persons at the Workplace; and
6. agrees that the designation as prime contractor hereunder may not be assigned or revoked without the prior written consent of the Owner.

Prime Contractor Name: _____

Prime Contractor Address: _____

Prime Contractor Signature **Date**

Print Name

Please return a signed copy of this designation to the City of Coquitlam, 3000 Guildford Way, Coquitlam, BC, V3B 7N2. If you have any questions, please contact the City of Coquitlam Health & Safety Manager at 604-927-3070.

Supplementary Contract Specifications

Supplementary Contract Specifications

to the
MASTER MUNICIPAL SPECIFICATIONS
Volume II – Platinum Book

**QUARRY ROAD ENHANCEMENTS
CONTRACT 74747**

TABLE OF CONTENTS

The following Supplementary Specifications are to be considered part of the Specifications. These Supplementary Specifications take precedence over the Master Municipal Specifications.

SUPPLEMENTARY CONTRACT

SPECIFICATIONS INDEX..... SS 1

00 72 43S	Contract Specific Notations	SS 2 to SS 6
01 33 01S	Project Record Documents	SS 7
01 45 00S	Quality Control.....	SS 8 to SS 10
01 53 01S	Temporary Facilities.....	SS 11
01 55 00S	Traffic Control, Vehicle Access and Parking.....	SS 12 to SS 14
01 57 01S	Environmental Protection.....	SS 15 to SS 18
01 58 01S	Project Identification	SS 19
03 40 01S	Precast Concrete.....	SS 20
31 05 07S	Aggregate and Granular Materials	SS 21 to SS 22
31 11 01S	Clearing and Grubbing	SS 23
31 11 41S	Shrub and Tree Preservation	SS 24
31 22 16S	Reshaping Granular Roadbeds.....	SS 25
31 23 01S	Excavating, Trenching and Backfilling.....	SS 26 to SS 27
31 24 13S	Roadway Excavation, Embankment and Compaction	SS 28 to SS 29
31 37 10S	Rip Rap	SS 30
32 11 16.1S	Granular Subbase.....	SS 31
32 11 23S	Granular Base.....	SS 32
32 12 13.1S	Asphalt Tack Coat	SS 33
32 12 16S	Hot-Mix Asphalt Concrete Paving.....	SS 34 to SS 36
32 17 23S	Painted Pavement Markings	SS 37 to 39
32 31 13S	Chain Link Fences and Gates.....	SS 40
32 91 21S	Topsoil and Finish Grading.....	SS 41 to SS 51
32 93 01S	Planting of Trees, Shrubs and Ground Cover.....	SS 52 to SS 65
32 31 13S	Pipe Culverts	SS 66

1.0	CONTRACT SPECIFIC INSTRUCTIONS	
1.01	Coordination of Work	The <i>Contractor</i> shall be responsible to consult with all affected businesses, residents, transportation companies regarding delays, detours, and any other works affecting any transit service in the area, and will be responsible to coordinate the works with City crews and other <i>Contractors</i> working in the area. If working area is to become a multiple-employer workplace as defined by WorkSafe BC, the <i>Contractor</i> shall remain the Prime <i>Contractor</i> .
1.02	Outside Agency Approval	In accordance with the Contract Documents, the <i>Contractor</i> is responsible to consult with and obtain any approval required to meet and comply with all the conditions required from outside agency such as, but not limited to, Province of BC for all instream Works , BC Hydro, Fortis BC Gas, Kinder Morgan, Telus, in the area of the place of Work where applicable.
1.03	Cooperation with Emergency and Maintenance Activities	The <i>Contractor</i> will be responsible to cooperate with regular maintenance or emergency vehicles and staff for access to the site when required including: <ul style="list-style-type: none"> • Fire, Police, and Ambulance • City Utilities Maintenance (or representatives) • City Parks and Recreation Maintenance (or representatives) • Other City <i>Contractors</i> • Metro Vancouver Parks
1.04	Site Safety	The <i>Contractor</i> is responsible to ensure the construction site is safe at all times for workers, pedestrians, and vehicle traffic. During non-working hours, the Contractor must ensure that the site has all potentially hazardous areas appropriately identified and protected, and also must provide appropriate signage, lighting, and markings for the direction of vehicle and pedestrian traffic, all to ensure the safety of the public. Supply and use of this equipment is considered incidental to the Contract.
1.05	Precautions	Protect areas under construction from damage caused by excessive erosion, flooding, heavy rains, etc. Repair or replacement of unprotected damaged areas and as directed by the Contract Administrator will be at no cost to the Owner.
1.06	Survey Layout	Construction layout will be the responsibility of the Contract Administrator as outlined in Supplementary General Condition 4.1.1.
1.07	Location of Existing Utilities	The <i>Contractor</i> is responsible to pre-locate and verify the size, depth and location of all utilities (watermains, storm mains, sanitary mains & etc.), including outside agency utilities (i.e. Telus, BC Hydro & etc.) and service connections (water, storm & sanitary services at the mains & property lines) by hand digging or by Hydro-Vac in the presence of the Inspector.

Pre-locates **must be completed as soon as possible after award of the Contract** so any changes can be completed by the Engineer prior to site construction. Contact BC One for location of outside agency utilities. The Contractor will not receive any compensation or allowance for delays if work is halted due to utilities & services connections not located prior to commencing construction.

City of Coquitlam does not guarantee water, storm or sanitary services connections are perpendicular to the mains or property lines, the *Contractor* will not receive any compensation for the time to locate these connections or for exposing hidden services at the property lines.

1.08 Verification of Dimensions and Quantities

Before proceeding with the work, the *Contractor* should visit the site and check and verify dimensions and quantities. Report variations between drawings and site conditions to the *Contract Administrator* before proceeding with work.

1.09 Approved Materials

A list of products that have been approved for use within the City of Coquitlam can be found on the City's website: [Approved Product List](#)

1.10 Widgeon Marsh Park and Quarry

Widgeon Marsh Park is open to the public and access must be maintained for the duration of the project. See <https://metrovancover.org/services/regional-parks/park/widgeon-marsh-regional-park> for more information.

2.00 CONSTRUCTION ACTIVITY

2.01 Pavement Markings

The *Contractor* will be responsible for temporary traffic markings necessary for traffic direction and safety until permanent markings are installed.

2.02 Site Clean-up During Construction and End of Construction

The *Contractor* will be responsible for the complete clean-up of the work site during construction and at the end of construction and prior to the Substantial Performance review.

The work will include cleaning of all catch basins periodically or as directed by the *Contract Administrator* within the Work area, or nearby location as affected by the Work. All cleaning is to be performed by vacuum truck to the satisfaction of the *Contract Administrator* and will include off-site disposal of waste material.

Payment for all work in this section is considered incidental to payment for work described in other Sections.

3.00 MANDATORY MEETINGS AND CONTRACTOR

**REPRESENTATIVES AND
SUBCONTRACTORS**

**3.01 Pre-Construction
Meeting Requirements**

After the Award of the Contract, the *Contractor* (Project Manager and Superintendent) will be required to attend a Pre-Construction Meeting with the *Contract Administrator* and provide all necessary information required by the *Contract Administrator* prior to provision of a Notice to Proceed. Items required to be provided at the meeting include:

1. A Detailed Construction Schedule showing the start date, completion date and the durations of major work components showing how all work will be completed within the Contract Duration.
2. Proof of Insurance.
3. Performance Bond and Labour and Materials Payment Bond.
4. WCB Clearance Letter and copy of Notice of Project.
5. City of Coquitlam Business License.
6. A copy of portions of your Health and Safety Plan including the Title Page, Table of Contents, and portion showing latest revision date.

**3.02 Pre-Construction
Meeting (Kw̓ikwəłəm
First Nation)**

A separate pre-construction meeting with the Contractor (Project Manager and Superintendent) will be required with Kw̓ikwəłəm First Nation to ensure total compliance with the Chance Find Procedures as established in Appendix B or the Nations Guardianship Program as outlined in Section 4.02.

**3.03 Contract Schedule,
Duration and
Sequencing**

A detailed, realistic construction schedule for this project will be required to be presented at the pre-construction meeting. The schedule must show major components and durations.

The Western Toad Migration will be occurring from approximately late June to early September and must be identified in the schedule. Please see section 01 57 01S – 1.04 for scheduling requirements.

All work under this project is to be completed within the designated Contract Duration as contained in the signed **Contract Agreement**, or as formally amended.

**3.04 Mandatory Bi-Weekly
Progress Meetings**

The Contractor will be required to attend progress site meetings at the place of Work, at bi-weekly intervals as agreed to with the Contract Administrator. Superintendent attendance is mandatory.

**3.05 Pre-Paving
Site Meeting**

The *Contractor* will be required to have a pre-paving meeting with their paving staff, on-site, just prior to paving to provide instruction regarding the existing grading and requirements for the paving process and the end product.

The *Contractor* must provide information to the *Contract Administrator*, for review, regarding proposed paving elevation control method, mat thickness control method, and rolling patterns.

The *Contract Administrator* must be in attendance at this meeting.

It will be the responsibility of the *Contractor's* Contract Superintendent to ensure continuity between the base preparation and the paving process.

**3.06 Contract
Superintendent and
Sub Contractors**

In compliance with the **MMCD General Conditions, Section 4.7, Superintendent**, the *Contractor* shall have a competent senior representative, (the "Superintendent") **in FULL TIME attendance** at the Place of Work while work is being performed for the duration of the contract.

This (FULL TIME) attendance is also required when work is being performed by Subcontractors.

Work done by Subcontractor is to be directed by the Superintendent and monitored on site ensuring conformance to the Contract Documents and other particular direction to the Superintendent by the *Contract Administrator*.

The Owner is not responsible for the direction of Subcontractor.

**3.07 Changes of Contractor
Representatives &
SubContractors**

The Superintendent and Subcontractor indicated in the Form of Tender shall not be changed unless:

1. The Owner requests a replacement.
2. The *Contractor* submits an application for a change, in writing, to the *Contract AdministAddrator* with the change being approved in writing.

**4.00 ENVIRONMENTAL /
ARCHAEOLOGICAL
REQUIREMENTS**

4.01 Environmental Notes

The City will obtain all necessary environmental approvals for the Work. The Contractor shall be responsible for complying with the terms and conditions specified within the various regulatory approvals and authorizations. In case of any conflict all terms and conditions in the approvals/authorisations shall prevail upon conditions given in Tender Documents.

**4.02 Kwikwəłəm First Nations
Guardian Program**

In the event of a guardianship program with **Kwikwəłəm First Nation (KFN)** the Contractor will be required to comply with **KFN personnelle**. The Guardian Program focuses on environmental, cultural and archaeological impacts of projects within KFN traditional territory.

KFN is interested in various aspects and stages of the project. Some key phases/activities that may lead to increased presence on-site include but are not limited to:

- Vegetation removal / grubbing
- In-stream work
- Excavation
- Wild life Surveys

The City's Contract Administrator (CA) will arrange an onsite meeting with the Guardian Manager, Guardian(s) and the Contractor's Superintendent, and the Contractor's Project Manager, prior to the start of construction. The purpose of the meeting will be to make introductions and open up lines of communication. The meeting will also provide the opportunity to review the construction schedule and phasing.

The Contractor will provide the CA, the Guardian, and fieldwork@kwikwetlem.com with a two week schedule of work, which the Contractor will update each week, while construction is underway.

The Contractor will be designated as 'Prime Contractor' for the construction site, and all attendees of the construction site, including the CA and the Guardian(s), will need to follow the safety protocols as outlined by the Contractor, to ensure a safe work site.

There will be open dialogue between the CA, the Guardian Manager, Guardian(s), and the Contractor. If the Guardian finds a situation where the Contractor is proceeding in a manner that is not acceptable with regard to environmental impacts (or a risk of environmental impacts), the Guardian will inform a Kwikwetlem Lands and Resources representative who will contact the Contractor's superintendent and the CA about the Guardian's findings. If the Contractor does not resolve the situation it will be up to the CA to determine the appropriate course of action in collaboration with a Kwikwetlem Lands & Resources representative.

The payments and fees for the Guardian Program will be responsibility of the City of Coquitlam.

END OF SECTION

1.0 GENERAL

1.3 Submission

Delete 1.3.2 and
replace with the
following

Submit one copy of an accurate project record document in final form prior to applying for Substantial Performance including any video report and test reports. Record documents to include changes in the Issued for Construction Drawings, new elevation, offsets & location of all utilities and any unknown/new utilities found on site. Legal holdbacks will not be released until complete record documents, including reports and manuals, have been submitted and accepted by the Contract Administrator.

Payment for all work performed under this section will be incidental to work in other Sections, unless otherwise described in Schedule of Quantities and Prices.

END OF SECTION

1.0 QUALITY

The *Contractor* shall provide a final product conforming to the Contract Documents and the intent of the work.

The work is to be accurate to the dimensional and tolerance requirements of the contract.

Payment will be subject to adjustments based on quality assurance tests performed by the *Contract Administrator*.

**1.01 Quality Control (QC)
by Contractor**

The MMCD (2009) definition of “Quality Control” is the process by which the Contractor checks specific materials, products, and workmanship to ensure strict conformance with the Contract Documents.

The *Contractor* is fully responsible for quality control of the materials, production, and construction processes.

Quality control tests shall be performed by the *Contractor*, at their own expense, to ensure that products meet the contract specifications.

Failure by the *Contractor* to conduct adequate quality control testing during production and construction will negate the *Contractor’s* ability to appeal the quality assurance tests used for acceptance/rejection of the work.

Under no circumstances will QC test results produced after completion of the Quality Assurance (QA) results be considered for appeal purposes.

Any changes in the Work with respect to the location, grade, or line shall be approved in advance by the *Contract Administrator*. Failure to notify the *Contract Administrator* of changes in writing may result in rejection of Work.

**1.02 Inspection of Work,
Quality Assurance,
and Material Testing,
by the Owner**

The MMCD (2009) definition of “Quality Assurance” means the process by which the Owner evaluates if the work is being constructed in accordance with the Contract Documents. This definition will be used for this contract

The *Contract Administrator* may provide construction review through spot inspections and spot materials testing for Quality Assurance.

Any materials testing results indicating a non-conformance to the Contract Documents will require construction corrective action by the Contractor.

All subsequent testing to corrective action to verify conformance to the Contract Documents will be the full responsibility of the Contractor.

Inspection review by the Owner will not relieve the *Contractor* from providing a product that meets or exceeds the requirements of the Contract Documents.

1.03 Inspection

Materials testing shall be as described in MMCD General Conditions, Section 4.12 with the following change:

Delete Section 4.12.2(a) and insert the following:

Where the MMCD specification clauses for Inspection and Testing indicate the *Contract Administrator* will arrange for all testing for work described in this section will be amended to read The *Contractor* will arrange for and pay for all testing for work described in this section. The testing shall take place at the following prescribed rates and as directed by the *Contract Administrator*. The *Contract Administrator* has the authority to call for testing, up to the rates and frequencies specified, at the *Contractors* cost.

All testing covered under this item shall be performed by a CCIL certified laboratory and technicians with copies of all test results to be sent directly to the *Contract Administrator*. Re-testing resulting from failed first tests shall be at the *Contractors* expense.

1.04 Testing

Contractor shall carry out inspection and testing (QC) to ensure compliance with Contract Documents. *Contractor* shall submit test results within one week of testing to the *Contract Administrator*.

The *Contractor* shall provide test results prior to the preparation of the payment certificate.

1.05 Contractors Responsibilities

Furnish labour and facilities to:

1. Provide access to work to be inspected
2. Facilitate inspections and tests
3. Make good work disturbed by inspection and tests

1.06 Access to Work

Allow inspection testing agencies access to Work.

1.07 Tests

Test rates and frequencies (excluding failed tests), when not defined in the MMCD or Detail Specifications Sections shall be at the following frequencies:

1. Trench Backfilling and Compaction

1.1 Compaction: 1 test / 25 lm / 300mm lift

1.2 Sieve: 1 test / placed material / 50 m³

2. Granular Base

2.1 Compaction: 1 test / 500m² / 100mm depth of granular base

2.2 Sieve: 1 test / placed material / 250 TONNES

3. Granular Subbase

3.1 Compaction: 1 test/500m² / 300mm depth of granular subbase

3.2 Sieve: 1 test / placed material / 250 TONNES

4. Embankment (Subgrade)

4.1 Compaction: 1 test/ 50m² / 300mm depth of fill

4.2 Sieve: 1 test / placed material / 100 TONNES

5. Asphalt

5.1 Marshall test: 1 test per 250 TONNES placed, per specified mix, min.
1 / day

ASTM D1559, D3203, C117, C136

5.2 Superpave: 1 test per 250 TONNES placed, min. 1 / day

CAI-SP2, ASTM D3203, C117, C136

5.3 Cores: 1 per 500 m²/lift

5.4 Continuous asphalt density testing during paving.

6. Subgrade Preparation

6.1 Compaction & Moisture: 1 test / 500 m²

7. Concrete Tests

7.1 Air, Slump & 1 Set Cylinders: 1 test / 10 m³, min. 1 set / day

Mix design, sieve analysis and all required reports to be submitted must be recent and dated within six months prior to construction.

**1.08 Measurement for
Payment**

Payment for all work performed under this section will be incidental to payment for work described in other Sections.

END OF SECTION

1.0 GENERAL

**1.6 Measurement for
Payment**

Add 1.6.2

Payment by allowance for Dewatering and Site Isolation includes the preparation and implementation of an approved Dewatering and Site Isolation Plan **per site**, including labour, material, equipment, and management of the creek water flow system (by-pass pumping) site isolation, dewatering, blocking, diversion) including supply, installation and removal of the temporary system, all equipment, materials, plugs and all associated works

The Contractor shall submit a **Dewatering and Site Isolation Plan for each site** to the Contract Administrator for review and approval. The Dewatering and Site Isolation Plan shall outline the Contractor's methodology for dewatering / isolating the work site(s) as well as a schedule outlining the timing of dewatering and flow diversions. The Contractor must submit the plan at least five (5) working days prior to any scheduled diversion(s). Dewatering and isolation systems shall not be solely relied on during non-working hours. Provisions must be made to allow safe conveyance of flow during non-working hours. The Contractor is solely responsible for any repairs that may be required following such an event.

Supply, installation and removal of temporary isolation facilities, as directed by the Contract Administrator and Environmental Monitor, to facilitate fish salvage operations. Fish salvage will be undertaken by the Environmental Monitor.

Retention and payment of fees for the QEP/Environmental Monitor will be the responsibility of the City.

Payment shall be made for the actual cost on a Force Account basis as defined in GC 10.0.

END OF SECTION

1.0 GENERAL

Add 1.0.6

The *Contractor* is responsible for all temporary traffic control required for completion of the work. The *Contractor* will be responsible to provide a Traffic Management Plan (TMP) for approval (10) ten working days prior to any disruptions taking place. TMP is to be prepared by a qualified professional following the requirements as specified in MoTI Traffic Management Manual for Work in Roadways, BC Construction Safety Alliance and WorkSafe BC.

The TMP shall outline the approach to traffic management, show recognition and minimization of risks indicates signing locations, identify Traffic Control Persons (TCP) stations and show proposed closures.

The *Contractor* is responsible to ensure and maintain City vehicle access at all times. The *Contractor* may provide temporary accesses at the City's approval. All costs associated with temporary accesses will be at the *Contractor's* expense.

Add 1.0.7

A Road and Sidewalk Closure Permit is required from Coquitlam for all work affecting pedestrian and traffic flow related to construction. A permit is required for each specific construction interference with pedestrian and traffic flow. The road and sidewalk closure permit form can be obtained for use from the City's website at <http://www.coquitlam.ca>. The Contractor must follow the approved TMP. Any changes to this TMP must be submitted to City's Traffic Operations for approval.

Add 1.0.8

Refer to Appendix A – Traffic Management Detail Specifications

A Road and Sidewalk Closure Permit is required for each instance of closure and will be valid for a maximum period of one (1) week and, if still necessary, re-submittal of a Road and Sidewalk Closure Request is required.

A copy of the approved Road and Sidewalk Closure Permit must be held on site by both the Site Superintendent and the person/company responsible for the traffic control implementation.

The Contractor must take the above information into account in the preparation and submission of the Tender.

Costs to complete the works taking the above restrictions into consideration shall be incidental to work described in other sections.

1.4 Traffic Control

Delete 1.4.1 and replace with the following

The *Contractor* shall conduct their operations so as to cause minimum obstruction and inconvenience to traffic and to places of business adjacent to the Place of Work. No greater quantity of work shall be undertaken at any one time than can be properly conducted with due regard to the rights and interests of the public as may be determined by the *Contract Administrator*.

The *Contractor* is to provide at all times safe and convenient means of approach and entrance to adjoining lanes, driveways, buildings and property both for vehicles and pedestrians to the satisfaction of the *Contract Administrator*. For this purpose, the *Contractor* shall construct and maintain suitable and safe platforms, approaches, structures, bridges, diversions or other works.

Where traffic must cross open trenches, the *Contractor* shall provide suitable bridges. Where trenches have been backfilled or where road improvements are incomplete the *Contractor* shall take any steps necessary to prevent potholes or other traffic hazards. Where the *Contract Administrator* so instructs or where Contract Specifications so require, the *Contractor* shall provide temporary asphalt patching of such hazards.

Add 1.4.9.3.1

The *Contractor*, as required by the *Contract Administrator* and the City, is to supply Construction Zone information signs (stationary), refer to MMCD 01 58 01 for the required identification signage.

The *Contractor* is responsible for the removal of the signs at the completion of the work.

Delete 1.4.10.1.3 and replace with the following

When workmen or equipment are employed over travelled way over brow of hills, around sharp curves or at other locations where oncoming traffic would not otherwise have adequate warning.

1.5 Measurement for Payment

Delete 1.5.1 and replace with the following

Payment for all work performed under this section including submission of Traffic Management Plan (TMP), Traffic Control Persons (TCP) & all temporary traffic signs, devices as required for traffic, trail users & pedestrian safety; and all other items described in the Traffic Regulation Section, and all labour, material, equipment and work described under **Appendix A: Traffic**

Management Detail Specifications shall be treated as incidental to payment for work described in other Sections unless shown otherwise in the Schedule of Quantities and Prices.

END OF SECTION

1.0 GENERAL

1.03

Add 1.03

The Erosion and Sediment Control (ESC) Supervisor is the Qualified Professional who is experienced in implementing ESC Plans and who is responsible for the inspection and monitoring of ESC Facilities to ensure these are installed and maintained in accordance with the ESC Plan, and if necessary, are modified during construction to ensure compliance with the Stream and Drainage System Protection Bylaw No. 4403, 2013.

Add 1.04

The Project will require work in a red coded watercourses that meets the definition of a 'stream' pursuant to the Water Sustainability Act.

The Contractor is responsible to understand and follow best management practices for working in and about a stream is contained within:

<https://www2.gov.bc.ca/assets/gov/environment/air-land-water/water/working-around-water/wsa-cias-requirements-bmps.pdf>

Add 1.05

Western Toad (*Anaxyrus boreas*) migration is likely to occur between late June to early September. Western Toads are a protected species under the BC Wildlife Act.

Guidelines for conservation of amphibians and reptiles can be found within:

**[Guidelines for Amphibian and Reptile Conservation During Road Building and Management Activities](https://www2.gov.bc.ca/assets/gov/environment/air-land-water/water/working-around-water/wsa-cias-requirements-bmps.pdf)
[finishDownloadDocument.do;jsessionid=3C1EE13B27C3E7AF634526C3ACE52CAD](https://www2.gov.bc.ca/assets/gov/environment/air-land-water/water/working-around-water/wsa-cias-requirements-bmps.pdf)
[fact-sheet-13-western-toad.pdf](https://www2.gov.bc.ca/assets/gov/environment/air-land-water/water/working-around-water/wsa-cias-requirements-bmps.pdf)**

Direct interaction with Western Toads will be prohibited.

Crews and construction workers may not capture, handle, or transport amphibians without a valid Wildlife Act amphibian salvage permit.

The Contractor will be required to establish wildlife exclusion fencing to mitigate the risk of wildlife access and interactions within the work areas. The Contractor will be required to daily and on a regular basis inspect the work area for the presence of wildlife and adopt

measures to mitigate adverse impacts or mortalities during construction.

Specific construction windows for grading and paving designated project segments will be required at the discretion of the Contract Administrator and coordination with the Qualified Environmental Professional (QEP) where isolation of the work zone is not possible.

1.2 Temporary Erosion and Sediment Controls

Delete 1.2.1 and replace with the following

Properly drain all portions of the site. Protect the site and the watercourses to which it drains, directly or indirectly, against erosion and siltation in accordance with a Sediment Control Plan under the City of Coquitlam Stream and Drainage System Protection Bylaw No. 4403, 2013 during construction and until the maintenance period is completed. Ensure no silt, gravel, debris or other deleterious substance resulting from construction activity discharges into existing drainage systems or watercourses or onto highways or adjacent property. The *Contractor* is responsible for all damage that may be caused by water backing up or flowing over, through, from or along any part of the work or otherwise resulting from his operations.

Keep existing culverts, drains, ditches and watercourses affected by the work clear of excavated material at all times. When it is necessary to remove or alter any existing drainage structure, provide suitable alternative measures for handling the drainage. Adequately support culverts and drainpipes across trenches to prevent displacement and interference with the proper flow of water due to trench settlement.

Follow all Federal and Provincial regulations and guidelines respecting protection of fish, fish habitat, and watercourses.

Add 1.2.2.9

All work within a watercourse must be undertaken and completed in isolation of all flowing water to maintain downstream water quality and unrestricted flows.

Add 1.2.2.10

Any fill used on this project shall be certified inert and from a source which is confirmed to be free of contaminants.

Add 1.2.2.11

All work within a watercourse must be undertaken and completed in isolation of all flowing water to maintain downstream water quality and unrestricted flows.

1.4	Environmental Protection	Add 1.4.3.5	Immediately contain and clean up any leaks and spills of prohibited materials at the <i>Place of Work</i> .		
		Add 1.4.3.6	Ensure that a well-stocked spill kit is on-site at all times and that the <i>Contractor's</i> employees are familiar with appropriate spill response techniques. Each spill kit will at a minimum have the following: <ul style="list-style-type: none">• 2 - 5 m long absorbent spill booms• 50 - 16" x 20" Sorbent Pads (Oil, Gas & Diesel)• 6 - 48" x 3" Sorbent Socks (Oil, Gas & Diesel)• 4 - 120" x 3" Sorbent Socks (Oil, Gas & Diesel)• 4 - 8" x 18" Sorbent Pillows (Oil, Gas & Diesel)• Nitrile Gloves• Hand Wipes• 2 - Disposable Respirators N958 HD• Hazmat Disposal Bags The Contractor is wholly responsible for costs associated with clean-up of spills originating from their equipment or work practices.		
		Add 1.4.3.7	Immediately notify the <i>Contract Administrator</i> and Environmental Monitor of any leaks or spills of prohibited materials that occur at the <i>Place of Work</i> .		
		Add 1.4.3.8	Ensure that any fuel stored on-site is located at least 15 metres from the nearest stream, and is placed within a bermed and lined area, in order to prevent leaks or spills into the environment.		
		Add 1.4.3.9	Ensure that no equipment fueling or servicing is conducted within 15 metres of a stream.		
		Add 1.4.3.10	During all phases of the operation, the Contractor shall take precautions to abate nuisance caused by mud or dust by clean up, sweeping, sprinkling with water or dust control, or other means as necessary to accomplish results satisfactory to the Contract Administrator.		
		1.6	Measurement and Payment	Delete 1.6.1 and replace with the following	Payment by allowance for all ESC measurements includes, labour, supply, installation, maintenance and removal.

The Contractor will be required to submit an ESC plan to the Contract Administrator at least 10 days prior to construction start for review and acceptance by the QEP.

Payment shall be made for the actual cost on a Force Account basis as defined in GC 10.0.

Add 1.6.2

Payment by allowance for Western Toad Environmental Protection, includes all labour, material, equipment, and management for all associated works.

The Contractor is required to coordinate with the appointed QEP and Contract Administrator to develop and implement individual site specific management plans.

Payment shall be made for the actual cost on a Force Account basis as defined in GC 10.0.

**1.9 Archaeological /
Historical
Resources**

Add 1.9

The Contractor must allow the Archaeological and Historical Resources group and Kwikwəłəm First Nation Guardians to perform duties around the site during construction. The Contract Administrator shall coordinate all other work being performed at the site with the Contractor.

Immediately cease work and inform the Contract Administrator and the City, if any archaeological or historical resources are encountered during construction. Leave these resources in place and do not disturb them in any way.

The Contractor MUST be familiar with the requirements for Chance Find Procedures as described in Appendix B.

END OF SECTION

**1.3 Measurement and
Payment**

Delete 1.3.1 and
replace with the
following

Payment for the installation of 1.2m x 1.2m static
construction notification signs as per Appendix A
includes supply, placement & removal and will be
incidental to payment for work described in other
Sections, unless shown otherwise in the Schedule of
Quantities and Prices.

END OF SECTION

1.4 Measurement and Payment

Delete 1.4.3 and replace with the following

Payment for concrete lock block retaining wall includes HALF SIZE & FULL SIZE BLOCKS, supply, excavation and disposal of surplus excavated material, , 19mm minus crushed granular base levelling pad, drainage chamber complete with geotextile (Nilex 4551 or approved equivalent), 25mm drain rock, wide chimney drain c/w non-woven geotextile, perforated pipe, and all work and incidentals associated with the Work as shown in the Contract Drawings.

Measurement of height of wall for the purposes of calculating areas for payment will be the facial area of the wall, including the buried area.

Payment will be made at the respective unit prices bid in the Schedule of Quantities and Prices.

END OF SECTION

1.4 Measurement and Payment Delete 1.4.1 and replace with Payment for 75mm minus pit run gravel (in accordance to Clause 2.3 Pit Run Gravel in Section 31 05 17 – Aggregates and Granular Materials), includes supply, transport, placement, adjustment of moisture content and compaction to 95% modified proctor density. Payment includes the offsite disposal of the unsuitable native material.

Payment will be made by measurement of volume confirmed by the tonne delivered to the Place of Work based on truck weigh slips. Weigh slips must be submitted to the Contract Administrator on a daily basis. Weigh slips which are not submitted daily will not be accepted for payment.

2.0 PRODUCTS

2.3 Pit Run Gravel Add to 2.3.2 The use of recycled concrete shall be approved by the *Contract Administrator* and the City prior to use.

Add 2.3.3 Asphalt millings free from contaminated and other extraneous material, conforming to the specified gradations may be used as pit run gravel. The use of asphalt millings shall be approved by the *Contract Administrator* and the City prior to use.

2.7 Granular Pipe Bedding and Surround Material Add to 2.7.1 All recycled or other extraneous materials shall be approved by *Contract Administrator* and the City prior to use.

2.10 Granular Base Delete 2.10.2
Add 2.10.3 All 25 mm minus granular base is to conform to the following gradation specifications:

Sieve Designation (mm)	Percent Passing (%)
25	100
19	80-100
12.5	75-90
9.5	50-85
4.75	35-70
2.36	25-50
1.18	15-35
0.30	5-20
0.075	0-5

Add 2.10.4

The intention of the Gradation Chart is to identify the desired mix of size of aggregate in the granular base. The Target Percentage Passing is the middle of the shown Range.

Tests that show sieve values of Percent Passing that are consistently low or consistently high in two (2) or more consecutive tests will be considered to be non-conforming.

**2.11 Recycled
Aggregate
Material**

Delete 2.11.1 and
replace with the
following

Aggregates containing recycled material may be utilized if approved by the Contract Administrator and the City. In addition to meeting all other conditions of the specifications, recycled material should not reduce the quality of the construction achievable with quarried materials. Recycled material shall consist only of aggregates, crushed portland cement concrete, or asphalt that is free of impurities.

END OF SECTION

1.4 Measurement and Payment

Delete 1.4.1 and replace with the following

Payment for all clearing and grubbing will be made at lump sum price and include removal and disposal of all branches, stumps, trees, debris, hedges, timbers, logs and vegetation to complete the work and as shown on the Contract Drawings or as directed by the Contract Administrator. Works include cutting of branches & falling of trees affected by Work to create the necessary clearance to accommodate the construction and intended function of the Work, and as shown on Contract Drawing

Payment includes trimming of small branches from trees or hedges as required, branch cutting/pruning to have a clean cut flush to branch collar and use of an approved tree paint to repair damage to surviving vegetation where branches have been removed.

END OF SECTION

SHRUBS AND TREE PRESERVATION

1.3	Measurement and Payment	Delete 1.3.1 and replace with the following	Payment for all work, unless included in the Schedule of Quantities and Prices, performed under this section will be incidental to payment for work described in other Sections.
2.0	PRODUCTS		
2.1	Materials	Add 2.1.10	Protective Fencing: Posts - Pressure treated wood 100 mm dia.; Post to be 1.8 m to 2.0m in height at 2.0 m O.C. Snow fence as per Coquitlam Approved Products List; Flagging Tape - 4" Orange glow - 'Tree Retention Area'.
3.0	EXECUTION		
3.1	Existing Trees	Add 3.1.7	The <i>Contractor</i> is responsible to minimize damage to all trees which are to remain.
		Add 3.1.8	The <i>Contractor</i> will be responsible for all claims and costs including the cost of examination by an Arborist, repair, removal and replacement of trees, as required by the Arborist, the <i>Contract Administrator</i> and the City for tree damage where proper notification was not received from the <i>Contractor</i> . Damage will be assessed based on the International Society of Arboriculture Guidelines. The term shall be for a period of one year following the date of Substantial Performance of the <i>Work</i> .
		Add 3.1.9	Place protective fencing/barricades as detailed on Coquitlam Standard Detail Drawings COQ-R26 in locations shown on the Contract Drawings. <i>Contractor</i> shall maintain fence in good condition during construction.
		Add 3.1.10	When work is to be performed inside fenced areas, <i>Contractor</i> shall take care to avoid damage to existing vegetation. Work to be done inside areas of existing vegetation to be retained includes: <ul style="list-style-type: none"> .1 Removal of isolated trees as directed by the <i>Contract Administrator</i> and the City. .2 Selective pruning and tree removal at edges to create tidy and well-shaped forest edge. .3 Placing planting soil and planting of trees.
		Add 3.1.11	Do not park, service or fuel vehicles within the vegetation retention areas.
3.4	Pruning	Add 3.4.2	Do not cut roots or branches of retained trees without approval of the <i>Contract Administrator</i> and the City.

END OF SECTION

1.4 Measurement and Payment

Delete 1.4.1 and replace with the following

Payment for reshaping existing bedding includes all spreading and grading of materials, adjustment of moisture content, compaction, boning and disposal of excess material offsite to establish the road existing cross-sections.

Delete 1.4.2 and replace with the following

Payment for additional granular base material required for reshaping described above will be made under Section 32 11 23S Granular Base.

Delete 1.4.3 and replace with the following

Payment for excavation of unsuitable materials including disposal off-site prior to reshaping granular roadbed will be made under Section 31 24 13S – 1.8.10 Roadway Excavation, Compaction and Backfill.

END OF SECTION

1.0 GENERAL

1.8	Limitations of Open Trench	1.8.1 Replace last sentence with the following	If circumstances do not permit complete backfilling of all trenches, and where permitted by the <i>Contract Administrator</i> and the City, adequately protect all open trenches or excavations with approved fencing or barricades and, where required, with flashing lights.
1.10	Measurement and Payment	Delete 1.10.3 and replace with:	Payment for over excavation including supply, placement and compaction of 20mm clear crushed backfill wrapped in Class 2 geotextile will be made on a volumetric basis at the unit rate tendered, and only for the volume authorized by the Contract Administrator. Payment to include removal and disposal of the unsuitable excavated native material.
		Delete 1.10.6 and replace with:	Payment for regrading new or existing stream channels or ditches will made on a volumetric basis at the unit price tendered. Payment will be made on before and after excavation cross section areas at sufficient intervals over the entire length of the channels or ditches.
		Add 1.10.9	Payment for installing each ditch block includes all labour, material and equipment required to complete the installation as shown on Contract Drawings
2.0	PRODUCTS		
2.2	Use of Specified Materials	Delete 2.2.1.2	Delete Pit Run Sand
		Delete 2.2.3.3	Delete Pit Run Sand
3.0	EXECUTION		
3.3	Excavation	Delete 3.3.1.2 and replace with the following	Connections to existing waterworks systems are to be made by the <i>Contractor</i> under the inspection / supervision of the <i>Contract Administrator</i> and the City.
3.6	Surface Restoration	Delete 3.6.2.4 and replace with the following	Restore lawns with approved topsoil and sod to match existing lawn.
		Delete 3.6.3.1 and replace with the following	Restore surface with a minimum 100 mm of 19 mm granular road base material.
		Delete 3.6.7.5 and replace with the following	Restore Pavement as detailed on Coquitlam Standard Detail Drawing COQ-G4. Temporary patch shall be a minimum thickness of 50 mm thickness. Permanent restoration to existing asphalt thickness (minimum of

75 mm) with a 35 mm key where existing thickness permits. A 50 mm key is required on Arterial and Collector Roadways. Dry if necessary and paint clean, dry edge with asphalt emulsion (tack coat).

END OF SECTION

1.8 Measurement and Payment

Delete 1.8.4 and replace with the following

Payment under this item will only apply to removal of the components included in this item under a separate operation as shown on the Contract Drawings or as directed by the *Contractor* Administrator. No payment will be made under this item for removal of these components as part of the operation for common excavation, and such removal will be treated as common excavation.

Payment will be made at the respective unit prices bid in the Schedule of Quantities and Prices and will include all labour, and equipment required to complete the work, including saw cutting and offsite disposal. It is the responsibility of the *Contractor* to locate and verify all utilities.

Delete 1.8.5 and replace with the following

Payment for Common Excavation includes:

1. Unless noted in the Schedule of Quantities and Prices as removal in square meters, common excavation will be measured in cubic metres calculated from measurements taken by the *Contract Administrator* in the areas of excavation.
2. Cross-sections will be taken after clearing and grubbing and after stripping of existing topsoil immediately prior to excavation of material to be incorporated into work.
3. Where determined by the *Contract Administrator* that truck box volume will be used to determine excavation quantities the volume per load shall be determined using full truck load volumes. The following is to be used for payment:

Truck Type	Material Type	Volume (cu.m.)
Tandem	ordinary material	7
Tandem	asphalt/concrete/pipe	4
Triaxle	ordinary material	8
Triaxle	asphalt/concrete/pipe	5
Tandem and Pony	ordinary material	11
Tandem and Pony	asphalt/concrete/pipe	7.5
Triaxle and Pony	ordinary material	13
Triaxle and Pony	asphalt/concrete/pipe	9
Tandem and Transfer	ordinary material	19
Tandem and Transfer	asphalt/concrete/pipe	13

4. *Contractor* to provide truck slips detailing location type of common excavation, time loaded and location of dump site. The slips are to be given to *Contract Administrator* by the end of shift or *Contract Administrator* can deny quantities subsequently submitted.
5. Payment for on-site re-use includes excavation, transport, temporary stockpiling, placement, compaction, boning, adjustment of moisture content, spreading and grading of material anywhere on site or within the work zone, as needed, to establish the roadway & pathway cross-section.

Payment will be made at the respective unit prices bid in the Schedule of Quantities and Prices and will include all labour, and equipment required to complete the work, including saw cutting and offsite disposal. It is the responsibility of the *Contractor* to locate and verify all utilities.

Temporary pole holds required to protect existing Hydro Poles in place in order conduct the Work as shown in the Contract Drawings will be considered incidental.

2.0 PRODUCTS

2.2 Specified Materials

Delete 2.2.1.3 Pit Run Sand.

Delete 2.2.1.4 River Sand.

Delete 2.2.2

END OF SECTION

1.4 Measurement and Payment Add to 1.4.1

Payment includes all labour, material and equipment required to complete the installation as shown on Contract Drawings and specified under this Section. Payment will be made for each type as specified in the Schedule of Quantities and Contract Drawings. Measurement will be for actual quantity placed based on weigh tickets provided to Contract Administrator as loads are delivered.

2.0 PRODUCTS

2.2 Filter Materials Add 2.2.2

Gravel Filter:
The rock weir shall be founded on gravel filter of 27.5mm crushed gravels meeting the gradation specified below:

Sieve Designation (mm)	Percent Passing (%)
37.5	100
25	85-100
12.5	20-100
9.5	0-70
4.75	0-20
1.18	0-10
0.3	0-5
0.075	0-2

END OF SECTION

GRANULAR SUBBASE

- | | | | |
|------------|--------------------------------|---|--|
| 1.4 | Measurement and Payment | Delete 1.4.1 and replace with the following | Measurement for granular subbase of variable thickness will be for actual quantity placed based on weigh tickets provided to Contract Administrator as loads are delivered. |
| | | Delete 1.4.2 and replace with the following | Measurement for granular subbase for each specified thickness will be for the actual area placed. |
| | | Delete 1.4.3 and replace with the following | Payment for Subsection 1.4.1 & 1.4.2 above includes supply, placement and compaction of granular subbase material, adjustment of moisture content, and boning to establish the road cross-section, shall be included in the unit price bid in the Schedule of Quantities and Prices. Payment includes submission of tickets as loads are delivered. Tickets not submitted within 24 hours of load delivery to site will not be paid. |
| | | Delete 1.4.4 and replace with the following | Payment for removal of unsuitable road structure, including disposal off-site prior to direct placement of granular subbase, will be made under Section 31 24 13S – Roadway Excavation, Embankment and Compaction. |
| 2.0 | PRODUCTS | | |
| 2.1 | Specified Materials | Delete | 2.1.1.1: Select Granular Subbase
2.1.1.2: 75 mm Pit Run Gravel
2.1.1.4: Pit Run Sand
2.1.1.5: Approved Native Material
2.1.1.7: River Sand |

END OF SECTION

GRANULAR BASE

1.4	Measurement and Payment	<p>Delete 1.4.1 and replace with the following</p> <p>Delete 1.4.2 and replace with the following</p> <p>Delete 1.4.3 and replace with the following</p> <p>Delete 1.4.4 and replace with the following</p>	<p>Measurement for granular base of variable thickness will be for actual quantity placed based on weigh tickets provided to <i>Contract Administrator</i> as loads are delivered.</p> <p>Measurement for granular base for each specified thickness will be for the actual area placed.</p> <p>Payment for Subsection 1.4.1 & 1.4.2 above includes supply, placement and compaction of granular base material, adjustment of moisture content, and boning to establish the road cross-section, factored into the unit price bid in the Schedule of Quantities and Prices. Payment includes submission of tickets as loads are delivered. Tickets not submitted within 72 hours of load delivery to site will not be paid.</p> <p>Payment for removal of unsuitable subgrade including disposal off-site prior to direct placement of granular subbase will be made under Section 31 24 13S – Roadway Excavation, Embankment and Compaction.</p>
2.0	PRODUCTS		
2.1	Granular Base	<p>Add 2.1.1.3</p>	<p>25 mm minus crushed gravel conforming to the gradation specifications for Collector/Arterial Roads under Section 31 05 17S – 2.10.3.</p>
3.0	EXECUTION		
3.5	Proof Rolling	<p>Delete 3.5.1 and replace with the following</p> <p>Add 3.5.7</p>	<p>For proof rolling, use fully loaded single axle, to 80 KN (18, 000 lb) minimum, dump truck.</p> <p>Prior to paving with asphalt concrete, the base surface shall be checked by the <i>Contract Administrator</i> and the City, for deflections utilizing a Benkelman Beam, in order to ensure that the final rebound requirements can be obtained with the asphalt pavement. In the event that such deflection is in excess of those required to produce the final standards, then the base shall be adequately strengthened by additional gravel or asphalt concrete to insure that final deflections as follows are not exceeded.</p> <p>The Benkelman spring rebound value of the completed pavement surface shall not at any point exceed 0.75 mm for arterial industrial roads and lanes, 1.15 mm for collector roads, and 1.5 mm for local roads and lanes as determined in the procedures outlined in the Transportation Association of Canada publication “Pavement Management Guide.”</p>

END OF SECTION

ASPHALT TACK COAT

- | | | |
|------------------------------------|---|---|
| 1.5 Measurement and Payment | Delete 1.5.1 and replace with the following | Payment for asphalt tack coat will be for surface area of all portions of existing pavement to be tack coated in preparation for placement of hot mix asphaltic concrete. |
| | Add 1.5.2 | Pavement surface cleaning, as per section 32 01 11, and all other work incidental to the application of tack coat is deemed to be incidental to payment for work described in other Sections unless shown otherwise in the Schedule of Quantities and Prices. |

END OF SECTION

1.0 GENERAL

1.4 Submission of Mix Design

Delete 1.4.1 and replace with the following

Submit asphalt concrete mix design, including RAP content and trial mix test results to *Contract Administrator* for review at least two weeks prior to commencing work.

1.5 Measurement and Payment

Delete 1.5.1 and replace with the following

Payment for asphaltic concrete paving includes all construction joint preparation, surface milling to tie into existing asphalt, saw cutting, supply and placing of the asphaltic concrete, compaction and taped temporary pavement markings.

Measurement for asphaltic concrete paving for the specified design mixes will be made at the respective unit prices bid in the Schedule of Quantities and Prices and incorporated into Work will be asphalt concrete actually based on weigh tickets provided to the *Contract Administrator* as loads are delivered. Payment includes submission of tickets as loads are delivered. Tickets not submitted within 48 hours of load delivery to site will not be paid.

The *Contractor* will not receive any additional compensation above the respective unit prices bid in the Schedule of Quantities and Prices for Hand Work, Special Equipment & Machinery to complete the Hot Mix Asphaltic Paving Work as shown on the Contract Drawings or as directed by the *Contract Administrator*.

Delete 1.5.3 and replace with the following

Payment for machine/hand placed driveways, pathways includes all construction joint preparation, tie-in to new or existing asphalt, saw cutting, supply and placing of the asphaltic concrete and compaction.

Measurement for asphaltic concrete paving for the specified design mixes will be made at the respective unit prices bid in the Schedule of Quantities and Prices will be made for asphalt concrete actually based on weigh tickets provided to the *Contract Administrator* as loads are delivered. Payment includes submission of tickets as loads are delivered. Tickets not submitted within 72 hours of load delivery to site will not be paid.

Payment for this item includes all applicable materials, specifications and work described in 1.5.1.

Add 1.5.9

The *Contractor* or the *Owner* may request adjustment of the unit prices submitted for Asphalt Pavement if the Composite Rack Posting (CRP) varies by more than 5.0%

from Tender Closing Date to the time the asphalt paving is actually performed.

The CRP is a composite of the available Rack Postings for PG 64-22 FOB Langley BC.

Requests for asphalt pavement unit price adjustment must be made prior to commencing asphalt paving. Payment for asphalt paving performed prior to a request for price adjustment will be made at the unit price submitted.

Unit prices will be increased or decreased as applicable using the following formula:

$$\text{Adjustment} = (\text{CRP}_{\text{work}} - \text{CRP}_{\text{tender}}) \times \text{AC}_{\text{volume}}$$

Adjustment is the amount in dollars per tonne the unit price is modified. CRP_{work} is the CRP at the time paving is performed. $\text{CRP}_{\text{tender}}$ is the CRP at the Tender Closing Date. $\text{AC}_{\text{volume}}$ is the mixture design percent asphalt content, by volume.

- | | | | |
|------------|-------------------------------|--|--|
| 1.6 | Inspection and Testing | Add 1.6.3 | Test cores are to be taken at the discretion of the <i>Contract Administrator</i> in the areas of new paving and will include cores along construction joints to ensure compliance with the required design and compaction. |
| 2.0 | PRODUCTS | | |
| 2.1 | Materials | Add 2.1.2.1 | Usage of recycled asphalt shingles or any other materials not specified in the Contract Documents will not be permitted. |
| | | Add 2.1.2.2 | Usage of softening agents, rejuvenators, or recycling agents will not be permitted. |
| 2.2 | Mix Design | Delete 2.2.2 and replace with the following | Mix may contain up to a maximum of 10 % by mass of RAP for Upper Course Asphalt and 15 % by mass of RAP for Lower Course Asphalt without a special mix design. The <i>Contract Administrator</i> and the City may approve higher proportion of RAP if <i>Contractor</i> demonstrates ability to produce mix meeting requirements of the specification. |
| | | Delete 2.2.3.2 Marshall Stability and replace with the following | Marshall Stability at 60°C for both lower and upper courses to be 10 KN min. |

3.0 EXECUTION

3.3 Preparation

Delete 3.3.3 and
replace with the
following

The *Contractor* is responsible for adjusting all utility manhole frames and valve boxes, belonging to Coquitlam and/or other agencies that are affected by the road works. All adjustments to utilities must be completed to the satisfaction of the utility owner. Utility adjustment within the paved surface will be considered incidental to the *Work* unless otherwise noted in the *Contract Documents*.

The *Contractor* should note that certain utility owners may decide to complete their own adjustments. The *Contractor* will be required to cooperate with any utility company providing their own adjustments.

The *Contractor* shall be responsible to contact the appropriate utility company with in minimum of seventy-two (72) hours of the work. No adjustment shall be made without the written approval of the utility company.

All manholes must be vertically adjusted a minimum of twenty-four (24) hours prior to paving. The use of riser rings for adjusting manhole frames and value boxes will not be permitted.

3.7 Joints

Delete 3.7.5 and
replace with the
following

Construct butt joints at locations as shown on the *Contract Drawing* and as directed in the field by the *Contract Administrator* and the City.

END OF SECTION

1.0 GENERAL

1.2 Scope

Delete 1.2.1 and replace with the following

Pavement Markings: Miscellaneous taped temporary and permanent pavement paint markings including pedestrian crosswalk, merge and diverge markings, stop lines, solid and broken line road lane markings including edge lines of merge and diverge markings, bike symbols, etc. to be provided as shown on the *Contract Drawing*.

1.5 Measurement and Payment

Delete 1.5.2 and replace with the following

All permanent markings shall be marked with thermoplastic road markings as specified under Section 32 17 23S, 2.1 Materials, unless shown otherwise in the Schedule of Quantities and Prices.

Delete 1.5.3 and replace with the following

The lump sum payment for permanent thermoplastic pavement markings covers supplying all materials and completing all the permanent thermoplastic pavement markings necessary to provide markings, including repainting of affected markings, as shown on the Contract Drawings.

NOTE: PAYMENT FOR PERMANENT THERMOPLASTIC PAVEMENT MARKINGS WILL NOT BE MADE UNTIL ALL TEMPORARY PAVEMENT MARKINGS AND REFLECTIVE DEVICES HAVE BEEN REMOVED.

Delete 1.5.4 and replace with the following

Payment for signage includes all sign poles, bases, sleeves, sign relocations, temporary removal, cleaning and re-installation of existing, and sign installations (complete). The City will supply signs as required in Schedule of Quantities and Prices. Payment includes all labor, materials and incidentals to complete the work.

- .1 Installation of each new sign pole, cap, sleeve and trapezoidal base or new sign pole with clamp onto a roadside barrier includes all costs to supply all materials, labour and equipment and incidentals, as shown on Standard Detail Drawings SS-E11.1 & SS-E11.2, necessary to the install sign structure as shown on the Contract Drawings and as directed by the Contract Administrator.
- .2 The unit price payment for each relocated or reinstated sign, pole, and base will include labour and equipment and incidentals necessary to remove, securely store, and re-install each sign as indicated on the Contract Drawings.

2.0 PRODUCTS

2.1 Materials

Delete 2.1.1 and replace with the following

Delete 2.1.6 and replace with the following

Delete 2.1.7 and replace with the following

All permanent paint markings shall be marked with thermoplastic manufactured by LAFRENTZ Road Markings, HITEX North America (HiBrite Extrude Thermoplastic), or ENNIS-FLINT (Extruded Thermoplastic). Pavement Markings:

Thermoplastic material

- .1 Material composition shall be at the discretion of the manufacturer subject to the approval of the *Contract Administrator* and the City. Each formulation shall be identified by a code number.
- .2 No retained water when tested by ASTM D-570.
- .3 Specific gravity of the supplied product shall be within 3 % of that specified for the selected formulation.
- .4 Material shall not deteriorate upon contact with deicing chemicals, gasoline, diesel fuel or grease dropped by traffic.
- .5 Material shall not break down, deteriorate, scorch or discolour, if held within the application temperature range specified by the manufacturer for a period of four hours and it must be able to be reheated from room temperature to the application temperature four (4) times without showing any of these detrimental effects.
- .6 When applied at the temperature recommended by the manufacturer and at a film thickness of 2 to 4 mm, the material shall set solid and show no tracking under traffic after elapsed times as follows:
 - .1 Two (2) minutes at an air temperature of 10° C, relative humidity less than 75 %, and road surface temperature from 10° C to 20° C.
 - .2 Five (5) minutes at an air temperature of 32° C, relative humidity less than 75 %, and road surface temperature from 35° C to 50° C.
 - .3 The drying time under conditions intermediate between the two air temperatures shall be interpolated using a straight line model.
- .7 The quantity, type, and gradation of the component reflecting glass spheres premixed in the thermoplastic material shall be at the discretion of

the manufacturer, but shall provide retroreflection levels specified below.

Add 2.1.1.11

Green Surface Treatment:

- .1 Material approved shall be "Traffic Patterns" thermoplastic by Ennis-Flint or MMA (Methyl Methacrylate).
- .2 The MMA Skid Resistant Material shall meet the following requirements:
 - .1 Be Ultra-Violet Stable.
 - .2 Be ISO Certified Durable Road Marking Material.
 - .3 Utilize 0.5mm – 1mm aggregate within the MMA to create skid resistance of 49 BPN.
 - .4 Green Colour (Pantone #) to be approved prior to application.
- .3 Product details and specification to be submitted to *Owner* for Final Approval.

3.0 EXECUTION

Add to 3.3.1.3

Temporary raised pavement markings (TRPMs) are to be provided on all collector and arterial roadways as directed by the *Contract Administrator* and the City.

3.3 Application

Delete 3.3.3.3 and replace with the following

Thermoplastic material shall be heated in the melter to a temperature of 382 °F.

END OF SECTION

1.5 Measurement and Payment

Delete 1.5.4 and replace with the following

Payment for the supply and installation of handrails includes supply and installation to complete the work as shown in the Contract Drawings and MMCD C14. Handrails to be powder coated black.

Add 1.5.5

Payment for Animex Wildlife Fencing (40" - AMX-SP) includes supply and installation of fencing, round wooden fence posts and all materials and incidentals to complete the work as shown in the Contract Drawings and specifications.

Coordination with on-site QEP to confirm depth of bury, installation best practices and limit of extents will be required prior to installation of fencing.

END OF SECTION

1.0	General Requirements	Delete 1.0.1 and replace with the following	.1 Section 32 91 21 refers to those portions of the <i>Works</i> that are unique to the supply, placement and finish grading of <i>Growing Medium</i> . This section must be referenced to and interpreted simultaneously with all other sections pertinent to the <i>Works</i> described herein. For the purpose of this specification, the term " <i>Growing Medium</i> " shall mean a soil produced offsite by homogeneous blending of mineral particulates, microorganisms and organic matter which provides suitable medium for supporting intended plant growth and the term " <i>Topsoil</i> " shall mean on-site native or surface soil material which may be used as <i>Growing Medium</i> provided it meets standards set for imported material <i>Growing Medium</i> and can be modified to meet the requirements set out for specified <i>Growing Medium</i> .
		Add 1.0.3	.3 For the purpose of this specification, the term ' <i>Soil-Testing Laboratory</i> ' shall mean an independent laboratory, recognized by the landscape nursery industry, with the experience and capability to conduct the testing indicated and that specializes in types of tests to be performed.
1.4	Measurement and Payment	Delete 1.4.1 and replace with the following	Payment for imported topsoil will include on-site handling, preparing the landscape area subgrade, placing, grading, raking, compacting top soil and application of fertilizers. Payment will be as specified in the Schedule of Quantities and Contract Drawings. Measurement will be for actual quantity placed based on weigh tickets provided to Contract Administrator as loads are delivered.
1.5	Inspection and Testing	Delete 1.5 and replace with the following	.1 The <i>Contractor</i> is responsible for testing imported <i>Growing Medium</i> and all related cost incurred. Testing shall be carried out by an approved <i>Soil Testing Laboratory</i> . .2 The sample analysis shall be of tests done on the proposed <i>Growing Medium</i> from samples taken at the supply source within a minimum of 14 days in advance of <i>Growing Medium</i> placement. Allow 7 days for soil testing by the laboratory for each sample. The sample shall be picked up by the <i>Soil Testing Laboratory</i> from the supply source. The <i>Growing Medium</i> sample shall be a composite of at least three (3) samplings for the proposed source and shall be at least one (1) litre in volume. .3 Forward a copy of all test results directly to the <i>Contract Administrator</i> and the City for review. The analysis shall outline the testing laboratory's required amendments such as sand, organic matter,

fertilizers and lime to achieve adequate growing conditions.

- .4 The *Contractor* shall not deliver any *Growing Medium* to the site until the test results have been reviewed and approved by the *Contract Administrator* and the City.
- .5 All submitted soil analysis must be dated and include supplier name and phone number, project location and submitted to *Contract Administrator* and the City for approval prior to commencing work. Soil analysis shall include measurements of:
 - .1 Percent sand, fines, silt and clay.
 - .2 Organic matter to 100%.
 - .3 pH, acidifying additive required to achieve noted herein.
 - .4 Water soluble salts.
 - .5 Total carbon to nitrogen ration.
 - .6 Total nitrogen and available levels of phosphorus, potassium, calcium & magnesium.
- .6 At the discretion of the *Contract Administrator* and the City submit up to two (2) additional samples, at intervals outlined by the *Contract Administrator* and the City, of *Growing Medium* taken from material delivered to the site. Samples shall be taken from a minimum of three (3) random locations and mixed to create a single uniform sample of testing. Results of these tests shall be forwarded to the *Contract Administrator* and the City for review.
- .7 The *Contractor* is responsible for soil analysis and requirements for amendments to supply *Growing Medium* as specified. Failure to satisfy these contractual requirements could result in the *Contractor* being required to remove unacceptable *Growing Medium* at their expense.
- .8 Notify the Contract Administrator at least forty-eight (48) hours prior to *Growing Medium* placement for inspection.
- .9 Refer to General Conditions, Clause 4.12 Tests and Inspections.

1.6 Product Handling Add 1.6

- .1 All materials to be handled and adequately protected to prevent damage. Do not handle *Growing Medium* in an excessively wet, extremely dry, frozen condition or in any manner in which structure may be adversely affected. *Growing Medium* whose structure has been damaged by handling under these conditions shall be rejected

and shall be replaced by the *Contractor* at their expense.

- .2 Stockpile materials in bulk form in paved areas or in pre-approved areas of the site. Provide additional protection of storage under roof or tarpaulins.
- .3 Take all precautions to prevent contamination of *Growing Medium* and amendments from wind blown soil particles, weed seeds and from insects. Contamination of the *Growing Medium* and amendments may result in their rejection for use.
- .4 Store fertilizer and chemical amendments in the manufacturer's original containers.
- .5 All *Growing Medium* shall be delivered to site premixed from a recognized *Growing Medium* source ensuring consistency throughout the mix.

2.0 PRODUCTS Delete 2.0 and replace with the following

2.1 Materials

- .1 *Growing Medium* Preparation
 - .1 Shall be prepared from Compost Material with Sand and other Soil Amendments as required to meet the specifications herein.
 - .2 Ensure commercial processing and mixing of *Growing Medium* components are done thoroughly by a mechanized screening process. Do not mix the components by hand. Ensure the resulting product is a homogeneous mixture having the required properties throughout free of stones 25 mm or larger in any dimension, woody plant parts, toxic materials, foreign object and other extraneous materials harmful to plant growth. Provide composted soil free from crabgrass, couch grass, equisetum, convolvulus, or other noxious weeds or seed or parts thereof.
- .2 Inorganic Soil Amendments
 - .1 Sand: Imported pit sand or river pump sand, free of impurities, chemicals, horsetails, and other noxious weeds. The saturation extract electrical conductivity of salinity shall not be greater than 3.0 milliohms/cm at 25 degrees C.

Sieve Size (mm)	Percent passing (%)
4.75	95-100
0.50	0-40
0.050	0-5

- .2 Fertilizers: Uniform in composition, free flowing and dry, granular, pill form, or pelleted

commercial product with 50% of total nitrogen (if applicable) derived from natural organic material in a slowly available form delivered in unopened water proof containers with the manufacturer's guaranteed N-P-K analysis, type and trade name attached to each container. The planting soil test results will specify a formulation and application rate to achieve the levels of nitrogen, phosphorous and potassium required. Fertilizer to meet the requirements of the Canada Fertilizer Act.

- .1 Lime: ASTM C 602, agricultural limestone containing a minimum 80 percent calcium carbonate equivalent and as follows:
 - .1 Class: Class T, with a minimum 99 percent passing through No. 8 (2.36 mm) sieve and a minimum 75 percent passing through No. 60 (0.25 mm) sieve.
 - .2 Provide lime in form of dolomitic limestone.
- .3 Perlite: Horticultural perlite, soil amendment grade.
- .3 Organic Soil Amendments
 - .1 Compost: Well-composted, stable, and weed-free organic matter, pH range of 5.5 to 8; moisture content 35 to 55 percent by weight; 100 percent passing through 25 mm sieve; soluble salt content of 5 to 10 decisiemens/m; not exceeding 0.5 percent inert contaminants and free of substances toxic to plantings; and as follows:
 - .1 Organic Matter Content: 50 to 60 percent of dry weight containing no cedar, redwood, wood or bark.
 - .2 Colour: dark brown to black in colour.
 - .2 Peat:
 - .1 Finely divided or granular texture, with a pH range of 6 to 7.5, containing partially decomposed moss peat, native peat, or reed-sedge peat and having a water-absorbing capacity of 1100 to 2000 percent.
 - .3 Wood Residual
 - .1 Content of wood residuals such as Fir or Hemlock sawdust present in the *Growing*

- Medium* shall not cause the total carbon to total Nitrogen ration to exceed 40:1.
- .2 Cedar or redwood sawdust shall not be present in *Growing Medium*.
 - .4 Manure
 - .1 Well-rotted, unleached, stable or cattle manure containing not more than 25 percent by volume of straw, sawdust, or other bedding materials; free of toxic substances, stones, sticks, soil, weed seed, and material harmful to plant growth and free from salt or other harmful chemicals, such as any used to artificially hasten decomposition.
 - .2 All particles in manure to pass a 6.35 mmm sieve.
 - .3 Salt content shall give a reading of less than 0.5 milliohms/cm at 25 degrees C.
- 2.2 Nutrient Requirements**
- .1 Nutrient requirements shall meet the BCSLA/BCNTA Landscape Standard *Growing Medium* requirements for nitrogen, phosphorus, potassium, calcium, magnesium, boron, sodium cation exchange capacity, carbon to nitrogen ratio.
 - .1 Boron: not to exceed 1.0ppm
 - .2 Sodium: Sodium absorption ratio(SAR) not to exceed 8.0
 - .3 Total Nitrogen: to be 0.2-0.4% by weight
 - .4 Available Phosphorous: to be 50-100 ppm
 - .5 Available Potassium: to be 50-70 ppm
 - .6 Cation Exchange Capacity: to be 30 to 50 meq.
 - .7 Carbon to nitrogen ratio: Maximum 40:1.
- 2.3 Salinity**
- .1 The electrical conductivity of the liquid taken from the soil pH evaluation shall not exceed 3.0 milliohms/cm at 25 degrees C before additions of fertilizers and/or liming agents.
- 2.4 Drainage Rate**
- .1 Percolation shall be such that mixing, handling and placement to be done in such a manner that the minimum saturated hydraulic conductivity show on Table - '*Growing Medium Properties for Different Applications*' (found herein these specifications) is achieved and no standing water is visible 60 minutes after at least 10 minutes of moderate to heavy rain or irrigation.
- 2.5 Growing Medium Source**
- .1 Import planting medium or manufactured planting medium from off-site sources. Do not obtain from agricultural land, bogs or marshes.
 - .2 Supplier of Growing Medium shall be as per the Coquitlam Approved Products List.

2.6 Bark Mulch

- .1 Mulch backfilled surfaces of planting beds and other areas indicated on drawings.
 - .1 Organic Mulch: Apply 50 mm average thickness of organic mulch, and finish level with adjacent *Finish Grades*. Do not place mulch against plant stems.
- .2 Supplier of Bark Mulch shall be as per the Coquitlam Approved Products List.
- .3 Dark brown in colour and free of all soil, stones, roots or other extraneous matter, and free of weeds, seeds and spores.

2.7 Growing Medium Properties for Different Applications

Properties	Low Traffic Lawn Areas, Trees and Large Shrubs	High Traffic Lawn Areas	Planting Areas, Planters Shrubs & Groundcover
Texture: Particle size classes by Canadian System of Soil Classification	Percent of Dry Weight Mineral Fraction (%)		
Gravel (greater than 2 mm less than 75 mm)	0-10	0	0
Sand (greater than 0.05 mm and less than 2 mm)	50-70	80-90	50-70
Silt (larger than 0.002 mm and less than 0.5 mm)	10-30	5-20	10-30
Clay (less than 0.002 mm)	7-20	2-5	7-20
Organic Content Percent of Dry Weight	5-10	3-5	25-30
Drainage Minimum saturated hydraulic conductivity (cm/hr) in place	2.0	7.0	2.0
Acidity (pH)	6.0-6.5	6.0-6.5	5.0-6.0

2.8 Miscellaneous Products

- .1 Root Barrier: 400x610 mm linear root barrier, copolymer polypropylene, 50% recycled plastic, black in colour. Supplier of Root Barrier shall be as per the Coquitlam Approved Products List.
- .2 Construction Adhesive shall be as per the Coquitlam Approved Products List.

- Clay: less than 0.002mm max 15%
- Clay and silt combined max 40%
- Acidity (pH) 6.0-7.0
- Drainage: minimum saturated hydraulic 3.0
- Conductivity (cm/hr) in place
- Salinity: saturated extract conductivity shall not exceed 3.0 milliohms/cm at 25 degC
- Organic content: percent of dry weight 8-12%
- 5 Stone ballast: Clean inert stone of high angularity is preferred over washed gravel. Stone dimension aspect ratio should be 1:1:1 with a maximum 2:1:1 length:width:depth. Single size stone, 60 mm-75 mm clear sieve designation: Blasted Quarry Rock. Aggregate to be used for structural soil shall be free of any foreign elements or material.
- .6 Structural Geotextile
Shall be installed as a structural filter layer directly above the compacted structural soil mixture. Do not install fabric until adequate compaction of the structural soil mixture has been confirmed. Filter fabric shall be selected and deigned to withstand wear and tear during construction without deterioration of its strength and filtering properties.
- .1 Supplier of Geotextile shall be as per the Coquitlam Approved Products List.
- .7 Ground dolomite limestone containing no less than 85% of its total weight as calcium carbonate and magnesium carbonate shall be used to control ph level. The degree of grind for the limestone shall allow 100% of the total weight to pass a #10 (2 mm) sieve, 90% to pass a #18 (1 mm) sieve and 20% to pass a #40 (0.105 mm) sieve. Spread-easy fertilizer shall be used as a slow release fertilizer source of calcium and magnesium.
- .8 Mixing of structural soil:
Blend as per following ratios:
- .1 5 metric tonnes (MT) of aggregate.
- .2 1 cubic meter of growing media.
- .3 2 kg soil stabilizer.
- .9 Moisten mixture with fine spray of clean potable water while mixing to activate soil stabilizer product. Do not over mix. Place mixture in 300 mm lifts through entire area of structural soil mixture. Compact each lift to 95% MPD prior to placement of next lift. Install filter fabric such to ensure a

minimum of 60 cm overlap of all fabric seams and beyond edge of structural soil.

3.0 EXECUTION

3.2 Preparation of Subgrade

Delete 3.2.4 and replace with the following

Remove debris, roots, branches, stones in excess of 50 mm diameter and other deleterious materials, soil contaminated with calcium chloride, toxic materials and petroleum products, and debris which protrudes more than 25 mm above the surface. Dispose of all removed material off site to approved offsite disposal area at no additional cost to the *Owner*.

Delete 3.2.5 and replace with the following

Course cultivate entire area which is to receive *Growing Medium* to depth of 250mm. Cross cultivate those areas where equipment used for hauling and spreading has compacted soil.

Add 3.2.6

Grade transitions shall be smooth and even and shall blend into surrounding areas as determined by the *Contract Administrator* and the City.

Add 3.2.7

Provide erosion-control measures to prevent erosion or displacement of soils and discharge of soil-bearing water runoff or airborne dust to adjacent properties and walkways.

3.3 Processing Growing Medium

Add 3.3.4

Growing Medium shall be imported and stockpiled on site in a location approved by the *Contract Administrator* and the City.

- .1 Carry out stock piling operation such that the *Growing Medium* structure is not compromised through compaction, vibration or other actions.
- .2 Stock piled *Growing Medium* shall be protected from rain, drying and contaminants.
- .3 *Growing Medium* shall be free of subsoil, pests, roots, wood, construction debris, undesirable grasses including crabgrass or couch grass, noxious or weeds and weed seeds or parts thereof foreign objects and toxic materials. Presence of these contaminants shall be grounds for rejection of *Growing Medium* and replacement at no cost to the *Owner*.

3.4 Placing Growing Medium

Delete 3.4.2 and replace with the following

Place *Growing Medium* to the required finished grades with adequate moisture, in uniform lifts of 100 mm to 150 mm compacted to 80 MPD during dry weather, over dry, unfrozen *Sub Grade* where planting is indicated free of any standing water.

Delete 3.4.5 and replace with the following

- Minimum depths after settlement and 80% compaction:
- .1 Trees pits: 900 mm
 - .2 Shrub beds: 450 mm

			.3 Ground cover areas: 300 mm
			.4 Lawn areas: 300 mm
			.5 Blvd. areas: 150 mm
		Add 3.4.6	Increase sand content to 90% in the planting soil below lawns where heavy wear by pedestrians or maintenance equipment is anticipated. Increase sand content in a 1.5m wide strip at the bottom of swales, banks or other wet areas and as directed by the Landscape Architect. On steep south or west facing banks, reduce sand content in lawns and planting beds to 50 - 60% for better moisture retention.
3.5	Applying Fertilizers	Delete 3.5 and replace with the following	.1 Addition of amendment components shall be at the rates indicated in the <i>Growing Medium</i> analysis recommendations via the following methods: .1 Lime: Applied with mechanical spreaders over entire planting areas and contained planters. .1 Do not apply by hand. .2 Mix thoroughly into the top 100 mm of <i>Growing Medium</i> . .3 Do not allow lime to come into direct contact with nitrogen - phosphate - potash fertilizers. .2 Fertilizer: Applied with mechanical spreaders over entire planting areas and contained planters. Do not apply by hand. Do not mix into <i>Growing Medium</i> .
3.6	Finish Grading	Delete 3.6.1 and replace with the following	Manually fine grade <i>Growing Medium</i> installation to contours and elevations shown on drawings or as directed by <i>Contract Administrator</i> and the City. Eliminate rough spots and low areas to ensure positive drainage.
		Add 3.6.3	<i>Finish Grade</i> of <i>Growing Medium</i> shall be 25 mm from finished elevation of adjacent curb or planter wall unless otherwise noted on drawings.
3.9	Clean-up	Delete 3.9 and add the following	.1 Ensure all paved areas, tops of planters, adjacent surfaces have been thoroughly cleaned. Ensure all discoloration of adjacent surfaces as a result of <i>Growing Medium</i> installation have been removed. .2 Dispose of materials not required and repair any damage to adjacent surfaces (as determined by the <i>Contract Administrator</i> and the City) off site at no additional cost to the <i>Owner</i> .
3.10	Weed Control	Add 3.10	.1 Ensure all weeds and weed roots that have germinated during the course of work of this section have been eliminated from <i>Growing Medium</i> .

- 3.11 Structural Soil** Add 3.11
- .2 Provide the City Representative and Consultant with a written outline of weed removal methodology seven (7) days prior to starting weed removal operations.
 - .1 Refer to 2.9 in this specification and as shown on the Contract Drawings.

END OF SECTION

1.0	GENERAL	Delete 1.0.1 and replace with the following	Section 32 93 01 refers to those portions of the Work that are unique to the sourcing, supplying, placing and maintaining the plant material indicated on the <i>Contract Drawing</i> and the Plant List(s). This section must be referenced to and interpreted simultaneously with all other sections pertinent to the Work described herein.
1.2	References	Delete 1.2.2 and replace with the following Add 1.2.4 Add 1.2.5	Canadian Nursery & Landscape Association (CNLA) Standard for Nursery Stock (current edition). The British Columbia Landscape & Nursery Association (BCLNA). ANSI A-300 Tree Pruning Guidelines
1.3	Source Quality Control	Delete 1.3 and replace with the following	<ul style="list-style-type: none"> .1 Seven (7) days prior to the <i>Contract Administrator</i> and the City review of plant material at source the <i>Contractor</i> shall confirm in writing availability of plant material noted on plant list. .2 Plant material will be supplied from nurseries who are certified by the Clean Plants program, Canadian Nursery Certification Institute (CNCI), current certification standard http://cleanplants.ca/. The certification shall include but is not limited to the requirements of the current active module(s), e.g. P. Ramorum module. The certification must extend to all fields and allied nursery operations where plant material is sourced. Only nurseries, fields and allied nursery operations that are certified will be permitted to supply plant material for this project. <ul style="list-style-type: none"> .1 Prior to the review of plant material by the <i>Contract Administrator</i> and the City the <i>Contractor</i> shall submit written documentation with CNCI certification stamp stating that the nursery has undergone all components of a certification program and has been audited to verify that all components are properly implemented. .2 The documentation submitted shall include but is not limited to the nurseries CNCI Clean Plants certification number. .3 Plant Material Review at the source nursery. <ul style="list-style-type: none"> .1 <i>Contractor</i> shall request for review of the plant material at source nursery to be a minimum of seven (7) days prior to scheduled review. .2 Shipping of plant material to the <i>Place of Work</i> shall not proceed until <i>Contract Administrator</i> has reviewed the plant material at the source nursery.

- .3 *Contract Administrator* and the City shall make one (1) visit to source nursery for review of plant material for entire project.
 - .4 All plant material, including substitutions shall be gathered at one location for review.
 - .5 *Contractor* shall accompany *Contract Administrator* during plant material review at the source nursery.
 - .4 Plant Material Review at the *Place of Work*
 - .1 All plant material shall be reviewed at the *Place of Work* by the *Contract Administrator* and the City prior to planting.
 - .2 Plant material that is rejected by the *Contract Administrator* shall be immediately removed from the *Place of Work* and replaced at the *Contractor's* expense.
 - .5 Imported Plant Material
 - .1 Plant material imported from out of province and out of country shall be accompanied with necessary federal and provincial permits and import licenses.
 - .2 The *Contractor* shall conform to all federal and provincial laws and regulations with regard to horticultural inspection of domestic and imported plant material.
 - .6 Condition of Plant Material
 - .1 Plant rootballs and containers shall be completely free of noxious weeds and volunteer plants including Horsetail and Morning Glory.
 - .2 Plant materials grown or supplied in Fabric Containers are not acceptable.
 - .7 All materials and execution to conform to the latest edition of the BCNTA Guide Specifications for Nursery Stock and the BCNTA Guide Specifications for Landscape Construction.
- 1.4 Submittals and Scheduling** Delete 1.4 and replace with the following
- .1 Submit inspection certificates as required by law for each shipment of plant material.
 - .2 *Contractor* shall provide in writing to the *Contract Administrator* and the City a minimum of seven (7) days prior to review of plant material at the source nursery a plant list confirming the quantity, botanical name, common name and size of plants specified.
 - .3 Substitutions
 - .1 *Contractor* shall provide in writing to the *Contract Administrator* and the City a minimum of seven (7)

- days prior to review of plant material at the source nursery a list of proposed substitutions for review.
- .2 Plant substitutions shall be of similar genus and species and of equal or greater size as those originally specified. The list shall contain the following information:
 - .1 Botanical name, common name of the specified plant
 - .2 Botanical name, common name of the proposed substitute plant
 - .3 Pot size and plant size in the nursery
 - .4 Planting Schedule
 - .1 *Contractor* shall provide in writing to the *Contract Administrator* and the City upon award of the *Contract* a detailed Planting Schedule outlining dates and duration of planting operations.
 - .2 Revisions to the Planting Schedule as a result of delays of any kind shall be submitted to the *Contract Administrator* and the City in a timely manner prior to the start of planting operations.
 - .3 Schedule all planting to ensure optimum environmental protection, grading, growing medium placement, planting, seeding, or sodding operations as outlined in these Specifications. Organize scheduling to ensure a minimum duration of on-site storage of plant material, minimum movement and compaction of growing medium, and prompt mulching and watering operations. Coordinate Work schedule with schedule of other trades on-site.
 - .4 Coordinate and schedule plating such that no damage occurs to plant material before and after placement. In particular, meet requirements of living plant material.
 - .5 Product Data
 - .1 *Contractor* to submit a one (1) litre sample of Composted Mulch to the *Contract Administrator* and the City for review prior to delivery.
 - .2 *Contractor* to submit a one (1) litre sample of the Prepared Growing Medium to the *Contract Administrator* and the City for review prior to delivery.
 - .3 *Contractor* to submit three (3) copies of the anti-desiccant manufacturer product data and specification for *Contract Administrator* and the City review.

1.5 Handling and Storage

Delete 1.5 and replace with the following

- .4 Contractor to submit three (3) copies of the fertilizer manufacturer product data and specification for *Contract Administrator* and the City review.
- .5 Contractor to submit three (3) copies of the Guying assembly including clamps, collar, guying wire, anchors and wire tighteners manufacturer product data and specifications for *Contract Administrator* and the City review.
- .1 Coordinate shipping of plant material and excavation of planting pits to ensure minimum time lapse between nursery digging and on site planting.
- .2 Ensure branches of trees and shrubs are bound securely into a confined mass during handling and transport.
- .3 Do not bind planting stock with rope or wire that would damage bark, break or damage branches or damage the natural shape of the plant.
- .4 Protect plant material against abrasion, and exposure to extreme temperature change during transit.
- .5 Cover plant foliage and branches with tarpaulin to prevent loss of moisture during transit.
- .6 Fully support root ball of large trees during all lifting operations.
- .7 Do not lift trees or shrub by the trunk or branches. Plant material to be moved by lifting the root ball or container.
- .8 Remove broken and damaged roots with clean cuts using sharp pruning shears.
- .9 Temporary Storage/ Heel-In of Plant Material onsite
 - .1 Temporarily store trees, shrubs and miscellaneous plant material that cannot be planted immediately by heeling-in. Acceptable heel-in material include approved growing medium or sawdust.
 - .2 Ensure temporary storage/heel-in area is shaded and protected from the wind.
 - .3 Provide sufficient water at regular intervals to ensure health of plant material in the temporary storage/heel-in area.
 - .4 Plant material that has not been properly maintained in the storage/heel-in area and illustrates signs of degradation or stress will be rejected by the *Contract Administrator* and the

City. Rejected plant material shall be replaced by the *Contractor*.

1.9 Measurement and Payment

Delete 1.9.1 and replace with the following

Payment by allowance for riparian restoration as directed by the Contract Administrator and identified by the QEP will include supply and planting of all trees, shrubs, and ground cover and includes all preparatory work, supply, planting and other incidental specified under this Section including maintenance to meet Conditions of Total performance.

Tree stock within riparian restoration areas will include, but are not limited to the following:

Tree: Douglas fir (*Pseudotsuga menziesii*)

Shrubs: Red Osier dogwood (*Cornus sericea*)

Willow (*Salix* sp)

Hardhack (*Spiraea douglasii*).

All restoration planting must be completed with guaranteed nursery stock (Trees #5 pot; Shrubs #2 pot) installed at 1m centers.

Payment shall be made for the actual cost on a Force Account basis as defined in GC 10.0.

1.11 Substitutions

Add 1.11

.1 If it is impossible to obtain the particular plant material listed, the *Contractor* may be permitted to suggest substitutions with types and variations possessing the same characteristics. The *Contractor* must request any substitutions of trees in writing at least one (1) month and shrubs and groundcover at least one (1) month prior to planting. Substitutions must be approved by the *Contract Administrator* and the City.

1.12 Plant Material Supply and Search Area

Add 1.12

.1 Before substitutions of plant material are proposed, documented proof that materials are not available through search on the west coast of Canada and United States must be provided. Area of supply shall include, but not be limited to, all of Western North America.

1.13 Plant Material Identification

Add 1.13

.1 Plant material that has been located by the *Contract Administrator* and the City and tagged for the project is to have the identification tags removed only after inspection and instruction by the *Contract Administrator* and the City after delivery to the *Place of Work*.

1.14 Plant Material Replacement

Add 1.14

1. The *Contractor* shall remove from the *Place of Work* and immediately replace any plant material that has been determined by the *Contract Administrator* and the City to have died or failed to grow in a satisfactory manner during the guarantee or maintenance period.
- .2 The *Contractor* shall extend the guarantee on this replacement plant material for one (1) year from the date of replacement.
- .3 The *Contractor* shall continue such replacement and guarantee of plant material until the *Contract Administrator* and the City has determined that the *Conditions for Total Performance* have been met.
- .4 All required replacements shall be plants of the same size and species as specified on the plant list and shall be supplied and planted in accordance with the drawings, specifications and change orders thereto.
- .5 The cost of replacements resulting from theft, accidental damage, vandalism, carelessness, neglect on the part of others, shall be borne by the *Contractor* until the date of *Substantial Performance*.

2.0 PRODUCTS

2.1 Plant Material

Delete 2.1 and replace with the following

- .1 Plant Material Size
 - .1 Overall plant spread to be measured when branches are in their natural position.
 - .2 Height and spread dimensions refer to main body of plant and not from branch tip to branch tip.
- .2 Grade of plant material to be No. 1 grade or better.
- .3 Plant material obtained from areas with milder climatic conditions from those of the *Place of Work* is acceptable provided:
 - .1 Plant material is moved to the *Place of Work* prior to the breaking of buds at their original climatic zone.
 - .2 Plant material is heeled-in at a protected area until the climatic conditions are suitable for planting.
- .4 Plant material shall have structurally sound, strong fibrous root system free of disease, insects, defects or injuries. All plants, typical of their species or variety, have a normal habit of growth and shall be first quality, sound, healthy, vigorous, well branched, and densely foliated, free of disease, insect pests, eggs or larvae.
- .5 Root Pruning at Source Nursery
 - .1 Plant material shall have been root pruned on a regular basis at the source nursery.

- .2 Plant material shall be root pruned at least one growing season prior to delivery.
- .3 Large trees shall be half root pruned during each of two successive growing seasons. The second root pruning shall have carried out a minimum of one growing season prior to delivery.
- .6 Shade, Ornamental and Evergreen Trees:
 - .1 Trees shall have straight trunks and a well-formed branch system which is characteristic of the species
 - .2 Trees shall exhibit clear signs of vigorous growth.
 - .3 Trees shall have good twig extension growth, branch spacing and trunk taper.
 - .4 Tree foliage shall be evenly distributed on upper 2/3 of the tree.
 - .5 Trees shall not have upright branches other than leaders.
 - .6 Trees shall have spreading branches with a single trunk and a single leader and, unless otherwise noted on plans or plant list.
 - .7 Tree trunks and branches shall not have any mechanical damage.
 - .8 Trees shall be in good health with no presence of insects or disease.
 - .9 Trees shall not have been 'headed back'.
 - .10 Tree root balls shall be solid, kept moist at all times and/or protected from drying.
 - .11 Trees shall not exhibit symptoms of root circling or girdling.
- .7 Container Grown Plant Material:
 - .1 Root ball to container relationship shall be of sufficient ratio to ensure room for healthy, vigorous root development.
 - .2 Plant material shall have been container grown for a minimum of one (1) growing season but not longer than two (2) growing seasons.
 - .3 The plant root systems that do not have the ability to "hold" growing medium when removed from the container will be rejected.
 - .4 Root bound plant material will be rejected.
- .8 Balled and Burlapped Plant Material:
 - .1 Coniferous and broadleafed evergreens over 2.4 metre tall shall be dug with firm soil root ball.
 - .2 Deciduous trees in excess of 3.0 metre height shall be dug with firm soil root ball.
 - .3 Root ball diameter shall be a minimum of 230 mm (for each 25 mm caliper size).

			<ul style="list-style-type: none"> .4 Secure root-balls with burlap, heavy twine and rope. .5 Large tree root balls shall be double layer burlap wrapped. Burlap to be secured with drum laces made up of 10 mm (minimum) diameter rope. .9 Tree Spade Dug Plant Material <ul style="list-style-type: none"> .1 Plant material shall be dug with mechanized hydraulic spade or clamshell type digging equipment. .2 Root ball diameter shall be a minimum of 230 mm for each 25 mm caliper size. .3 Wire basket shall be lined with burlap. Root ball shall be laced and tied to wire basket with heavy rope. .4 Ensure trunk of tree is not damaged by wire basket, ties or rope.
2.2	Water	Delete 2.2.1 and replace with the following	Potable and free of minerals and impurities which are detrimental to plant growth.
2.3	Fertilizer	Add 2.3.2	Fertilizer shall be prolonged-release fertilizer tablets containing a minimum of 20% nitrogen, 10% phosphoric acid, and 5% potash (20-10-5) as per Approved Products List. Store in weatherproof storage space.
2.4	Mulch	Delete 2.4.1 and replace with the following	Composed mulch shall be 9 mm black/brown in colour with no cedar or redwood bark or wood material as per Approved Products List.
2.5	Stakes	Delete 2.5.1 and replace with the following	Stakes shall be pressure treated Hem/Fir, 75 mm dia. round, 2500 mm long. Stake fasteners shall be hot dipped galvanized or stainless steel.
2.8	Guying Wire	Delete 2.8.1 and replace with the following	Guying wire shall be direct burial or screw type disc guy anchor and guy system as per Approved Products List.
2.11	Anti-Desiccant	Delete 2.11.1 and replace with the following	Anti-Desiccant shall be wax-like emulsion, as per Approved Products List, that will provide a transpiration reducing film over the plant surface.
2.12	Flagging Tape	Delete 2.12.1 and replace with the following	Flagging tape shall be 30mm wide 'Red' PVC flagging tape as per Approved Products List.
2.13	Tree Trunk Protection	Add 2.13	.1 Tree trunk protection shall be extrusion mold process, polyethylene with UV protectors as per Approved Products List.

2.14	Burlap	Add 2.14	.1 Burlap shall be untreated, free from toxic contaminants and of sufficient strength to hold the rootball in a compact, stable mass that does not move relative to the main stem(s) of the tree or shrub.
2.15	Wire Baskets	Add 2.15	.1 Wire baskets shall be non-galvanized metal basket designed and manufactured for the purpose of tree moving. Basket shall be shaped to ensure that the root ball will allow a stable planting condition in accordance with standards noted.
2.16	Tree Ties	Add 2.16	.1 Tree ties shall be Flat woven polypropylene material. 20 mm wide, 544 Kg, break strength, extrusion mold process, polyethylene with UV protectors as per Approved Products List.
3.0	EXECUTION		
3.1	Pre-Planting Operations	Delete 3.1 and replace with the following	<p>.1 Place stakes on site to identify location trees, shrubs and plant beds in accordance to the Landscape Plans.</p> <p>.2 <i>Contract Administrator</i> and the City to review all tree locations and plant bed layout prior to start of plant bed preparation and planting operation.</p> <p>.3 Anti-desiccant shall be applied only as directed by the <i>Contract Administrator</i> and the City. Application of anti-desiccant shall be in accordance with manufacturer's instructions.</p> <p>.4 Coordinate planting operations with other trades and project schedule.</p> <p>.5 All planting operations shall be done in a timely manner in accordance to the Planting Schedule.</p> <p>.6 Planting Schedule shall be updated as required by the <i>Contractor</i> to coincide with status of site and coordination with other trades. Provide the <i>Contract Administrator</i> and the City with updates to the schedule as required throughout the planting process.</p>
3.2	Subgrade Preparation	Delete 3.2 and replace with the following	<p>.1 The <i>Contractor</i> is responsible for confirming the location and extent of existing utilities prior to the start of all planting operations. All attempts should be made to ensure that utility services are maintained to all on and off site parties throughout the entire planting operation.</p> <p>.2 Tree Pits</p> <p style="padding-left: 20px;">.1 Tree Pit Depth 900 mm minimum.</p> <p style="padding-left: 20px;">.2 Width of tree pit shall be a minimum of 450 mm to 600 mm greater than diameter of the root ball.</p>

3.3 Planting

Delete 3.3 and
replace with the
following

- .3 Prior to the placement of growing medium scarify the sides and bottom of tree pits created with a tree spade to eliminate glazed surface.
- .3 Ensure tree pits dug in heavy or compacted soils exhibit the ability to drain freely by filling each tree pit with a minimum of 20 litres of water. Water should freely drain through subsoil within ten (10) minutes.
 - .1 Notify *Contract Administrator* and the City if tree pits in any soil condition do not drain freely or if tree pit fills with ground water.
 - .2 There shall be no standing water in the bottom of tree pit at time of planting.
- .4 Protect bottom of tree pit(s) against freezing.
- .5 Ensure tree pits and plant beds are kept well drained and free of contaminants and construction debris.
- .6 Planting Areas shall be excavated to the following depths:
 - .1 Shrub beds, perennials, ornamental grasses shall be 450 mm.
 - .2 Ground covers and annual flowers shall be 300 mm.
 - .3 Trees shall be 900 mm.
- .1 Planting operations shall be carried out under conditions that are conducive to healthy, vigorous growth of plant material.
- .2 Plant material shall be planted vertical, straight and plumb at locations staked in field and or noted on landscape plans.
- .3 Ensure orientation of plant material will give best appearance in relation to views from adjacent buildings, roads, walks or use areas.
- .4 Ensure planting depth of root ball is equal to the depth of root ball originally established in the nursery. The top of root ball shall be level with adjacent growing medium.
- .5 Ball and Burlap Plant Material: After plant has been lowered into plant bed or tree pit cut away all root ball ties from around trunk. Loosen burlap from around trunk and cut away minimum top 1/3 without disturbing root ball.
- .6 Container Grown Plant Material: Remove entire container (including biodegradable containers) without disturbing root ball. Score root ball vertically at six (6) locations evenly spaced around entire root ball to minimize girdling of roots.

- .7 Tree Spade Dug Root Balls: Cut wire basket around entire perimeter of root ball. Bend down top 2/3 of wire basket without disturbing root ball. Cut away all root ball ties from around trunk. Loosen burlap from around trunk and cut away minimum top 1/3 without disturbing root ball.
- .8 Backfill planting areas in 150 mm lifts to 2/3 of the depth tamping each lift of growing medium around root system to eliminate air voids. Do not use frozen or saturated growing medium for backfill operation.
- .9 Prior to placing remaining growing medium, thoroughly water planting areas, fill tree pits with water. Complete backfill operation only after water has completely penetrated into growing medium.
- .10 Build 100 mm high by 150 mm wide (4" high by 6" wide) saucer around outer edge of tree pit to assist with maintenance watering.
- .11 Tree Stabilization
 - .1 Guy or stake trees as directed by *Contract Administrator* and the City.
 - .2 Ensure guy pins and stakes are not placed through the root ball.
 - .3 Trees that have had root balls penetrated by guy pins and stakes will be rejected.
 - .4 Tie one (1) to two (2) flagging tape flags to all guy wires at a height that is clearly visible.
- .12 Place tree trunk protection around base of tree trunk as per manufacturer instructions.
 - .1 Trees 100mm caliper or less shall have one protector. Do not interlock ends of tree protector.
 - .2 Trees greater than 100mm caliper shall have a minimum of two interlocked protectors. Do not interlock outside ends.
- .13 Fertilize as per recommendations based on soil testing and place planting tablets at the following rates in prepared planting holes. Spread the tablets in each hole before planting.

	<u>Plant/Container Size</u>	<u>Table Size</u>	<u>Tablets per Plant</u>
.1	Trees	21g	1 per every 1.25mm of trunk caliper
.2	#15/ 45 cm tub	21g	3
.3	#7/ 35 cm tub	21g	3
.4	#5/ 30 cm pot	21g	2
.5	#3/ 27 cm pot	21g	2

			.6	#2/ 21 cm pot	21g	1
			.7	#1/ 15 cm pot	21g	1
3.4	Tree Support	Delete 3.4 and replace with the following	.1	Guy and stake all trees immediately after planting. Plant material not guyed or staked immediately shall be replaced if damaged.		
			.2	Drive one (1) stake per tree vertically into the ground to a depth of 750 – 1000 mm, in such a manner so as not to injure the root or root ball.		
			.3	Fasten tree to the crotch and midway between the crotch and the ground with galvanized wire protected by hose.		
			.4	Trees to stand plumb upon completion of this operation.		
3.6	Pruning	Delete 3.6 and replace with the following	.1	All pruning cuts shall be made with pruning saws or hook and blade pruning tools designed and manufactured for pruning operations. Anvil-type pruning tools shall not be used in any pruning operations.		
			.2	Prune trees and shrubs after planting operation as directed by <i>Contract Administrator</i> and the City.		
			.3	Prune each tree and shrub planted to preserve the natural character of the plant and in a manner appropriate to its particular requirement in the landscape design. Pruning in general shall be heavier on collected than on nursery-grown plants. Remove all soft wood sucker growth and all broken or badly bruised branches with a clean cut.		
			.4	Employ clean sharp tools and make cuts without damaging the branch collar.		
			.5	Do not damage the leader or lead branches. Plants which have had the main leader or lead branches damaged or removed will be rejected and replaced by the <i>Contractor</i> at no cost to the <i>Owner</i> .		
			.6	Do not remove minor twig branches along the main structural branches.		
3.7	Mulching	Delete 3.7 and replace with the following	1.	Prior to the application of composted mulch;		
			.1	Manually remove all weeds and weed roots from root balls and adjacent growing medium.		
			.2	Remove all deleterious material and debris from planting areas.		
			.3	All fine grading shall be completed, the growing medium shall be loose and friable.		

- .4 The *Contract Administrator* and the City has reviewed of all planting areas.
- .2 Spread composted mulch to minimum depth of 50 mm.
- .1 Ensure finish composted mulch layer is a minimum of 12 mm below adjacent hard landscape surfaces and edges.
- .2 Ensure mulch is kept 125 mm away from tree trunks and 75 mm away from stems of shrubs.
- 3.8 Clean-up** Delete 3.8 and replace with the following
- .1 Growing medium spilled onto pavement and growing medium stains on pavement or adjacent hard surfaces shall be cleaned up immediately.
- .2 Remove from the site all pots, cans, surplus materials, and other debris resulting from planting operations.
- .3 Ensure complete removal of planting tags, labels, strings, or other materials prior to Substantial Performance.
- .4 Neatly dress and finish all planting areas and flush all walks and paved areas clean to the satisfaction of the Consultant and *Owner*.
- 3.9 Maintenance** Delete 3.9 and replace with the following
- .1 Maintenance of plants shall begin immediately after planting operation and shall continue in an uninterrupted fashion until all deficiencies noted in the *Substantial Performance* review have been rectified and the *Contract Administrator* and the City has provided to the *Contractor* written confirmation of the date of *Total Performance*.
- .2 If for any reason the *Contractor* elects, on his own without the written consent of the *Contract Administrator* and the City to suspend maintenance operations, the *Contractor* shall provide the *Contract Administrator* and the City written notice of such action. Any damages or requirement for the replacement of plant material that as a result of the suspension of maintenance operations shall be the borne by the *Contractor* at no cost to the *Owner*.
- .3 Maintenance of plant material includes but is not limited to watering at intervals sufficient to maintain healthy, vigorous growth, weeding of plant beds and tree pits, cultivating of growing medium, pruning, treatment of insects, molds, fungi or disease to the Level 2 "Groomed" as per the BCNLA Landscape Standard, Current Edition or as directed by consultant.

- .4 Plant material shall be deep watered at least once per day when temperatures exceed 25 degrees Celsius.
- .5 Water sufficiently to maintain soil moisture conditions for optimum establishment, growth and health of plant material without causing erosion.
- .6 Supply equipment such as pumps, portable sprinklers systems, tank trucks, hose and sprinklers required for watering operations. Water trucks, if used for watering operations, must service the site from adjacent roads until irrigation system is operational.
- .7 *Contractor* to ensure adequate moisture in plant root zone prior to winter freeze-up.
- .8 Reset all plants that have settled to plant depths approved by the *Contract Administrator* and the City prior to the placement of composted mulch.
- .9 Ensure tree guards, stakes, flagging tape on tree guy wire and tree ties are kept secure, taught and in proper repair.
- 3.10 Conditions for Total Performance** Delete 3.10 and replace with the following
- .1 Conditions for *Total Performance*:
- .1 *Substantial Performance* shall have been granted by the *Contract Administrator* and the City and, Final Inspection at the end of the guarantee/warranty period.
- .2 All plant material is healthy; exhibiting signs of vigorous growth and meets the requirements of this specification.
- .3 Plant material installed less than ninety (90) days prior to frost will be accepted in following spring, thirty (30) days after start of growing season provided that final acceptance conditions are fulfilled.
- .4 Unless otherwise indicated in the *Contract Drawing* the original shape and form of the plant as reviewed by the *Contract Administrator* and the City has been maintained, leaders are intact, there are no wounds or abrasions on trunks or branches.
- .5 Mulch has been maintained to specified depths.
- .6 All planting areas continue to be free draining with no signs of standing water.
- .7 All plant beds are completely free of weeds and noxious grasses.
- .2 The *Contractor* shall continue to maintain the work of this section until the *Contract Administrator* and the City provides written confirmation that *Total Performance* conditions have been met.

END OF SECTION

1.0 GENERAL

1.5 Measurement and Payment

Delete 1.5.2 and replace with the following

Payment for all work under this Section and as shown on Contract Drawings will be as described under individual payment items in Schedule of Quantities and Prices.

Payment under this item includes excavation and disposal of surplus excavated material, existing culvert removal and offsite disposal regardless of size and material, bedding, import backfill, supply of all concrete pipe and related materials, construction joints, temporary utility pole supports, and all other work and material necessary to complete the installation as shown on the Contract Documents and specified under this Section.

Pipe bedding shall be 19 mm clear crushed rock or as approved by the *Contract Administrator* and the City.

Measurement for pipe culverts will be made horizontally from end to end of the culvert after the work has been completed.

Add 1.5.7

Payment for the supply and installation of concrete box culvert complete with reinforcement as required, includes excavation, disposal of surplus excavated material, removal and disposal of existing pipes regardless of size and material as required, site preparation, culvert bedding, imported engineered substrate or organic material, temporary utility pole supports and all other work and material necessary to complete the installation as shown on the Contract Documents.

END OF SECTION

Appendix A - Traffic Management Detail Specifications

These supplementary Specifications must be read in conjunction with the Master Municipal Specifications contained in the Master Municipal Construction Documents (Platinum), Volume II, 2009.

- 1.0 GENERAL**
- 1.1 Related Works
- 1.2 References
- 1.3 Project Requirements
- 1.4 Measurement and Payment
- 2.0 PRODUCTS**
- 2.1 Traffic Management Plan
- .1 This Traffic Management detail specification refers to the Contractor’s specific plans to identify project traffic risks affecting the *Work*, provide Traffic Control Plans, and to implement the traffic control for the safe passage of vehicles and pedestrian through the work zone.
 - .1 Traffic Regulation MMCD Section 01 55 00S.
 - .1 WorkSafe BC, Occupational Health and Safety (OHS) Regulation, Section 18 – Traffic Control.
 - .2 B.C. Ministry of Transportation (MOT) Traffic Control Manual for Work on Roadways.
 - .1 A Road and Sidewalk Closure Permit is required by Coquitlam for all work affecting traffic flow related to construction. A permit is required for each specific construction interference with traffic flow. A digital copy of the Road and Sidewalk Closure Permit form can be obtained for use during the contract from the City’s website at www.coquitlam.ca/closure.
 - .2 A Road and Sidewalk Closure Permit form application must be submitted to the City’s Traffic Operation Division 10 working days prior to start of work.
 - .1 For this Contract, payment for all work performed under this section, unless included in the Schedule of Quantities and Prices shall be treated as incidental work, including a Traffic Management Plan (TMP), Traffic Control Persons (TMP), traffic markings & all temporary traffic signs, devices as required for traffic & pedestrian safety; and all other items described in the Section 01 55 00S.
 - .1 The Contractor is required to assign a Traffic Manager for the Contract with the responsibility of preparing the Traffic Management Plan and the Traffic Control Plans, as well as the responsibility for continuing implementation of traffic control for the Work.
 - .2 The Traffic Management Plan (TMP) will consist of the following components:
 - .1 Category identification through risks and project category assessment as per MOTI Traffic Management Manual for Work on Roadways;
 - .2 Traffic Control Plans for individual stages of the construction;
 - .3 Incident Management Plan for the response to an unplanned event and recording of incident information;

These supplementary Specifications must be read in conjunction with the Master Municipal Specifications contained in the Master Municipal Construction Documents (Platinum), Volume II, 2009.

- .4 Category 3 TMP must be signed and sealed by a qualified Professional Engineer.
 - .3 Submission of the TMP is to be made to the *Contract Administrator* within five (5) days of the *Notice of Award* of the *Contract*, and must be approved by the *Contract Administrator* prior to start of the *Work*.
 - .4 Review of the TMP will be performed by the Contract Administrator. Comments for revisions to the TMP will be returned to the *Traffic Manager* for implementations.
 - .5 The Contractor shall comply with all the requirements of applicable laws, rules, regulations, codes and orders of the municipal and other appropriate authorities concerned with work on streets or highways and shall post proper notices and/or signals, and provide necessary barriers, guards, lights, flagmen or watchmen as may be necessary for proper maintenance of traffic and protection of persons and property from injury or damage. All costs involved in respect to the above requirements will be deemed to be included in the Contract Price.
 - .6 The Contractor shall give due notice to local police and fire departments prior to beginning construction and shall comply in all respects with their requirements.
 - .7 The Contractor, during the progress of the work, shall make adequate provision to accommodate the normal traffic along streets and highways immediately adjacent to or crossing the work so as to cause the minimum of inconvenience to the general public.
 - .8 The Contractor is required to maintain local traffic and driveway access during all stages of construction.
- 2.2 Incident Management and Reporting
- .1 The Contractor shall facilitate incident response vehicles and staff and move traffic safely and expeditiously through or around an incident on site and provide assistance to emergency response personnel as required. An incident includes, but is not limited to, motor vehicle accidents, emergency road repairs, disabled vehicles, and debris on the road. The immediate response to an emergency shall by necessity make use of available devices and equipment.
 - .2 If an incident occurs on site, the Contractor will be required to submit a report to the Contract Administrator documenting details of the incident including event, location, date, time, action taken, duration and restoration of site.

These supplementary Specifications must be read in conjunction with the Master Municipal Specifications contained in the Master Municipal Construction Documents (Platinum), Volume II, 2009.

- 2.3 Traffic Control Plans
- .1 The Contractor shall designate a qualified Traffic Control Supervisor for the works, per the requirements of WCB regulations Section 18. The designated Traffic Control Supervisor may be the same individual that is designated as the Traffic Manager, or may be a separate individual qualified for the responsibilities of this function.
 - .2 The Contractor shall prepare weekly the anticipated traffic control activities, locations, and durations for the upcoming week.
 - .3 Permissible delays shall only be considered outside Peak Hours. Permissible delays are categorized as follows:
 - a) Minor Delays - Less than two (2) minutes in duration; for occasional interruption due to construction activities. These delays shall be coordinated with available breaks in the traffic flow.
 - b) Major Delays - Maximum five (5) minutes in duration; for occasional interruption of traffic for construction activities if traffic volumes permit. These delays shall be coordinated with available breaks in the traffic flow.
 - .4 The Contractor is responsible for ensuring that the flow of traffic is unimpeded by construction-related activities.

3.0 EXECUTION

- 3.1 Traffic Control Plan
- .1 A copy of the approved current Traffic Plan must be held on site by both the Site Superintendent as well as the person/company responsible for the traffic control implementation.
 - .2 Failure to produce a valid approved Traffic Plan on site, or having work not follow the Traffic Control Plan will result in immediate shut-down of the work. The Contractor will be required to safely restore facility conditions to allow traffic flow at their expense. The Contractor must take all steps to acquire an approved Traffic Control Plan before work can re-start on site. No claim will be accepted by the Owner for costs associated with this work shut-down.
- 3.2 Road and Sidewalk Closure Permits
- .1 The Contractor must have, on-site, a copy of an approved Road and Sidewalk Closure Permit valid for the work being done. Failure to produce a valid Road and Sidewalk Closure Permit on-site will result in shut-down of the work. Failure to comply on what is stated on the approved permit will result in shut-down of the work. The Contractor will be required to safely restore facility conditions to allow traffic flow at their expense. The Contractor must take all steps to acquire a Road and Sidewalk Closure Permit before work can re-start on site. No claim will be accepted by the Owner for costs associated with this work shut-down.

These supplementary Specifications must be read in conjunction with the Master Municipal Specifications contained in the Master Municipal Construction Documents (Platinum), Volume II, 2009.

- 3.3 Traffic Control Personnel & Equipment
- .1 The Contractor shall supply all necessary traffic control devices required to perform traffic control services for the project. Signs and traffic control devices not applying to existing conditions shall be removed. Where operations are carried out in stages, only those traffic control devices that apply to the current stage are to be left in place.
 - .2 There must be sufficient Traffic Control Persons (TCPs) on site to appropriately and safely direct traffic in all sections of the Work.

- 3.4 Signage
- .1 Supply, installation, maintenance and removal of all works-related signs shall be the responsibility of the Contractor. The location and type of each sign shall be indicated on the approved Traffic Control Plan, for each stage of the works.

Traffic control signs and devices must be positioned and used as specified in the Traffic Control Plan and signs and devices must be located so as to allow traffic to move by or through the work area in a controlled manner and, if necessary, to come to a controlled stop with due regard for the prevailing weather and road conditions.

Signs shall be checked daily for legibility, damage, suitability and location. Signs and delineators shall be cleaned as frequently as necessary to ensure full legibility and reflectance.

- 3.5 Detours
- .1 Detours will not be permitted.

- 3.6 Abrupt Changes in Surface Elevations
- .1 The Contractor shall minimize any abrupt changes in roadway elevation left exposed to traffic during both working and non-working hours.

- 3.7 Cyclist and Pedestrian Access
- .1 The Contractor shall make provision for pedestrians, wheel chairs and bicycles to have safe access across the work zone at all times.

4.0 TRAFFIC RESTRICTIONS

- 4.1 Road and Sidewalk Closure Permits
- .1 A Minimum of Single Lane Alternating Traffic must be accommodated at all times.
 - .2 A City of Coquitlam Road and Sidewalk Closure Permit is required for each instance of closure and will be valid for a maximum period of one (1) week and, if still necessary, re-submittal of a Road and Sidewalk Closure Request is required.

A copy of the approved Road and Sidewalk Closure and Lane Closure Permit must be held on site by both the Site Superintendent and the person/company responsible for the traffic control implementation.

These supplementary Specifications must be read in conjunction with the Master Municipal Specifications contained in the Master Municipal Construction Documents (Platinum), Volume II, 2009.

.3 Total Road Closure is Not Permitted

- 4.2 Lane Closure Restrictions
- .1 **For each of the road sections affected:**
- Road and Sidewalk Closures will be reviewed for appropriateness during the allowable hours of work.
 - Access to properties to be maintained.
 - Sufficient Traffic Control Persons are required for each Road and Sidewalk Closure (or any work activities), including side street intersections, to safely guide traffic through the work site.

- 5.0 HOURS OF WORK**
- .1 **The hours of work shall be from 0700h to 1900h inclusive Monday to Friday and 0900h to 1800h inclusive Saturdays , unless noted otherwise.**

6.0 CONSTRUCTION OPERATIONS

- 6.1 Truck Routes
- .1 The Contractor is restricted to the City's designated Truck Routes. The current Truck Route Map is available on the City's website at www.coquitlam.ca and can be found under Residents, Transit & Transportation, Trucking Routes.
- 6.2 Road Specific Considerations
- .1 Ensure that Traffic Management Plan accommodates residences during construction activities.
- 6.3 Work Stoppage Due to Traffic
- .1 The City will not control or direct traffic control activities of the Contractor, but may require an immediate stop to any work where, in the sole opinion of the Contract Administrator, the provided traffic management plan is ineffective or creating unreasonable delays.
- 6.4 Construction Activity and Signage
- .1 The Contractor will be responsible to place other construction information signs as required to inform the public of construction activities, and ensure safe travel through the work site.
- 6.5 Construction Zone Information Signs
- .1 The Contractor is required to provide, one week prior to start of work, stationary signs, to inform traffic of existing and anticipated conditions at entry points to be worked on. Exact locations to be determined on site by Contract Administrator.

Construction Zone Information Signs to follow specifications below:

These supplementary Specifications must be read in conjunction with the Master Municipal Specifications contained in the Master Municipal Construction Documents (Platinum), Volume II, 2009.

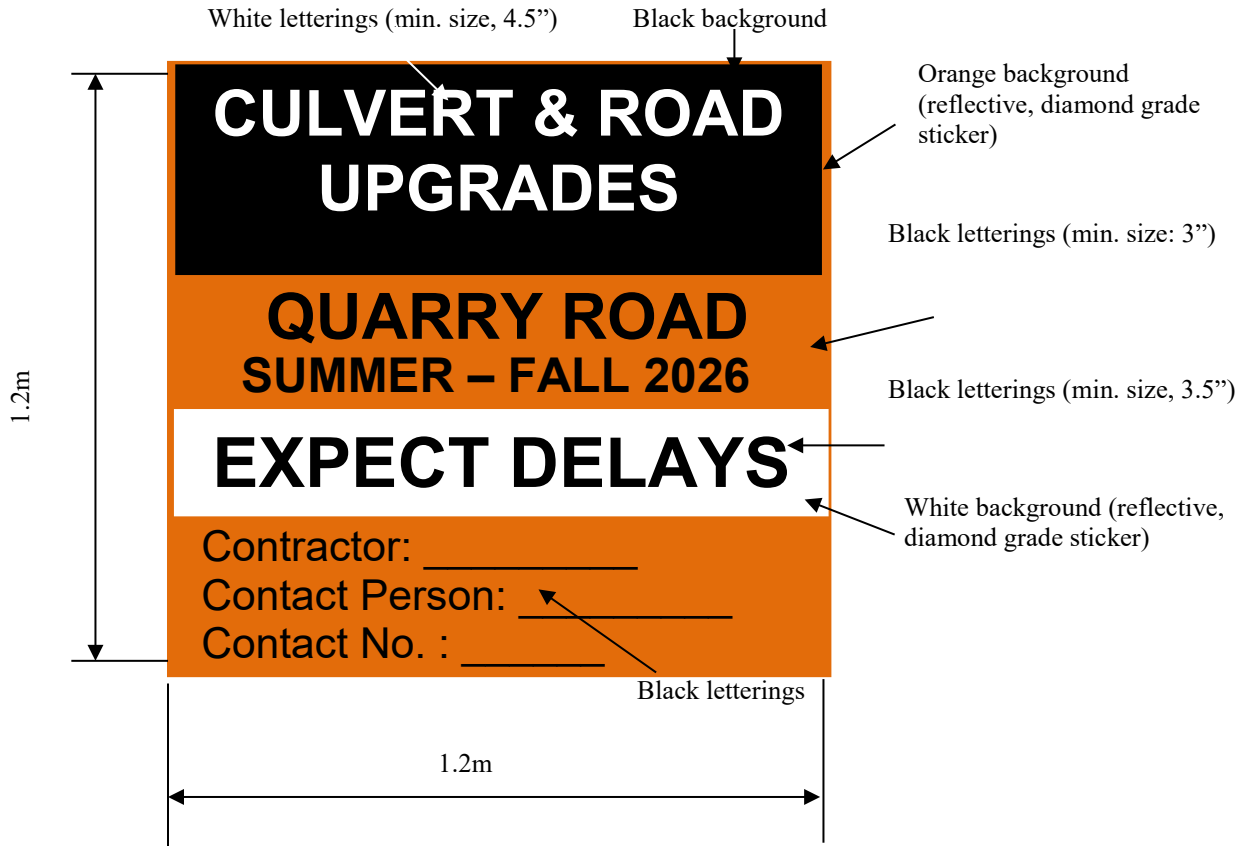

These supplementary Specifications must be read in conjunction with the Master Municipal Specifications contained in the Master Municipal Construction Documents (Platinum), Volume II, 2009.

APPENDIX 1



City of Coquitlam
**Road and Sidewalk
Closure Permit Request**

Traffic and Street Use Management Section
3000 Guildford Way, Coquitlam BC V3B 7N2

Phone: [604-927-6250](tel:604-927-6250) Email: StreetPermits@coquitlam.ca

~~Initial Permit: \$150~~ ~~Renewal Permit: \$75~~

74747

Application Date: _____ City Project or Film Permit Number (if applicable): _____

- An Initial Permit is required for all new applications and when the location, type of work, or the type of traffic controls change from what was approved for the Initial Permit. The application needs to be received a minimum of 10 business days prior to the intended closure date.
- A Renewal Permit extends the rights and privileges of the approved Initial Permit and is required when the timeline needs to be extended. The application must be received a minimum of 5 business days prior to the intended extension date.

Development Site Address (if applicable): _____

Work location (street name, block number, to/from, at, etc.) _____

Contact Information

Applicant Company Name: _____

Applicant (person completing application form)

Name: _____ Title: _____

Phone: _____ Email: _____

Applicant's Signature: _____

Company Name (Prime Contractor): _____

Site Superintendent

Name: _____ Title: _____

Phone: _____ Mobile: _____ Email: _____

Permit Information

Start Date: _____ End Date: _____

Day(s) and Time(s): Monday Tuesday Wednesday Thursday Friday From: 00:00 To: 00:00
 Saturday From: 00:00 To: 00:00 Sunday From: 00:00 To: 00:00

Specific Lanes: Curb Inside/Centre Lane Left Turn Lane Right Turn Lane Parking Lane
 All Lanes Sidewalk/MUP Bicycle Lane

Direction: Northbound Southbound Westbound Eastbound

Purpose of Work: Concrete Pour Utility Installation Curb Installation Other _____

This permit is related to: City Design and Construction City Parks External Environmental
 Development External/Utilities

City Contact (if applicable): _____

Office Use Only

Permit Conditions/Comments:

Approved by _____

Date _____

Application Checklist



The following information must be provided. Incomplete applications will not be reviewed.

1. Traffic Management Plan (TMP); **OR**
 Traffic Management Manual for Work on Roadways Figure Number: _____
2. **Project Category Determination** (per [2020 Traffic Manual for Work on Roadways](#)).
 Initial Project Category Assessment
 Project Risk Analysis
 Category 1 Category 2 Category 3
3. **Prime Contractor Designation Letter**
4. **City of Coquitlam Certificate of Insurance**
5. **Notification Letter and Map** (required for all full road closures). A Notification Letter must be provided to all affected residents and businesses.
 Yes No Not Applicable
6. **Traffic Control Persons** (flag persons) **required?** All operations within the road right-of-way must comply with WorkSafe BC regulations and BC Ministry of Transportation standards for work on roadways.
 Yes No If yes, how many? _____
7. **Bus routes/stops impacted?** Applicant is to contact Coast Mountain Bus Company (with a minimum of 3 days' notice) [Temporary Transit Changes Request Form](#). General information can be found by visiting [Temporary Transit Changes](#).
8. **City of Coquitlam Solid Waste has been contacted?** Coquitlam Environmental Services contacted regarding impact to garbage/recycling routes and pick up Phone: [604-927-4300](tel:604-927-4300) Email: wastereduction@coquitlam.ca
 Yes No
Are operations impacted? Yes No
If Yes:
 - a plan to ensure continuous collection has been provided: Yes No
 - Day(s) of the week impacted: _____
 - Time(s) of the day impacted: a.m. p.m.
9. **Pedestrian / Bike Lanes impacted?** Please describe sidewalks and/or bicycle facilities that will be impacted by the proposed work.

10. **Is the work on, or will it impact a road along our [Major Road Network](#)?**
 Yes No

Additional information

- Only vehicles actively engaged in the performance of cleaning, clearing, maintenance, repair, construction or other work are permitted within work zones. Vehicles being used by Superintendents, Traffic Control Persons, and other construction personnel that are not actively engaged in work described above are not permitted within the work zone and are not permitted parking /stopping prohibitions.
- Closures of sidewalks, cycling facilities, lanes, and full road closures are only permitted during the time periods indicated on the approved permit. Traffic controls are not permitted outside of these approved permit hours.

***Appendix B -
Archaeological Chance Find
Procedures***

Archaeological Chance Find Procedures City of Coquitlam

DRAFT 2

November 2021 (version 2)



Table of Contents

Introduction.....	3
Purpose	3
Archaeological Sites in British Columbia	4
HCA Legislation and Policies	4
First Nation Cultural Heritage Management.....	4
Potential to Encounter Archaeological Sites	6
Types of Archaeological Sites.....	6
Archaeological Chance Find Procedure.....	6
Archaeological Chance Find Procedure - Suspected Ancestral (Human) Remains.....	7
Management Options	7
Best Practices for CFP Implementation	8
Contact List	10
Archaeological Site and Materials Identification	10
Artifacts	10
Beads	12
Indigenous Historical Artifacts.....	12
Hearths	13
Fire-Altered Rock	13
Shell and Non-Shell Midden	14
Surface Features	15
Rock Shelters and Caves	15
Ancestral (Human) Remains.....	15
Petroglyphs and Pictographs (Rock Art).....	16
Fish Weirs and Traps	17
Wet Sites.....	17
Culturally Modified Trees (CMTs)	18
Additional Resources	19
References Cited	19

Introduction

This document is presented as an accompaniment to Kwikwetlem Cultural Heritage and Archaeology Chance Find Procedures training provided by Brown & Oakes Archaeology to City of Coquitlam (or the “City”) staff and contractors.

The Chance Find Procedure (CFP) is intended to provide City planners and onsite project personnel guidelines for the appropriate response to an unanticipated discovery of known or suspected archaeological or cultural heritage materials during City operations. A CFP is NOT a substitute for professional archaeological assessment of project areas considered to hold archaeological potential. Thorough archaeological assessment will always reduce project risk of harms to protected archaeological sites and minimize the potential for encountering unanticipated material. This CFP training is intended to promote the preservation and proper management of heritage resources that are unexpectedly encountered during City activities.

The document presents a summary of archaeology site protection legislation, steps to follow in the case of suspected or observed archaeological materials, a list of appropriate authorities to contact in the case of archaeological site encounters, and a guide to archaeological site and materials recognition. Information on Kwikwetlem culture history and connections to traditional lands is not presented in this document and this information is best shared via virtual or in-person presentations.

Purpose

The purpose of CFP documentation is to aid in the protection and proper management of archaeological materials encountered during City of Coquitlam activities. Many land-altering activities have the potential to expose and/or negatively impact undocumented archaeological materials.

The purpose of this document is to:

- Ensure project personnel are aware that undocumented archaeological sites are likely to be present in the City of Coquitlam.
- Promote awareness of activities that may lead to the exposure of archaeological materials, including excavations, vegetation clearing, field survey and inspections, and more.
- Provide personnel the appropriate steps to follow if suspected or observed archaeological resources are encountered during work or personal activities.
- Provide education and resources to assist recognition of archaeological site types and materials in the lower Fraser River region.

Archaeological Sites in British Columbia

Archaeological sites are places that exhibit physical evidence of past human activity. Archaeological sites in British Columbia are automatically protected under the *Heritage Conservation Act* (HCA) when located on provincial, crown, municipal, or private land¹. The vast majority of archaeological sites in BC include places and belongings of Indigenous peoples. Some post-1846 sites related to newcomer history may also be registered and protected under the HCA if of significance to a place, industry, or region, for example. HCA protection is extended to ship and plane wrecks more than 2 years old.

Many First Nations consider the widely accepted definition of an archaeological site as a place featuring only the material remains of human activity too restrictive and instead advocate for the recognition and protection of a wider range of “cultural heritage” site types, including places of spiritual significance, named locales, known travel routes, and other places of cultural value.

The majority of the City of Coquitlam has not been surveyed for archaeological sites and it is reasonable to expect that many archaeological sites are buried and/or undetected. These sites are collectively referred to as undocumented archaeological sites.

HCA Legislation and Policies

Archaeological sites are automatically protected under the terms of the *Heritage Conservation Act* whether known or undocumented. Sites are protected whether previously disturbed by historic activities or intact. The HCA prohibits the alteration or disturbance of archaeological sites in whole or in part, on provincial public and private lands, whether impacts are intentional or inadvertent, and irrespective of previous land disturbance.

The HCA provides substantial penalties for the destruction or unauthorized disturbance of archaeological sites including imprisonment for up to two years and fines of up to \$1,000,000.

Alterations to archaeological sites may proceed under appropriate HCA permits held by professional archaeologists following provincial assessment guidelines². Work plans and methodologies related to archaeological site investigations must meet provincial regulatory standards and are expected to conform to participating First Nation cultural heritage policies and best-practice standards.

Archaeological materials on federally managed lands may be protected by other legislation and policies. Many federal agencies will adhere to the requirements outlined in the *HCA* when managing archaeological sites.

¹ <http://www.for.gov.bc.ca/archaeology/index.htm>.

² The HCA is administered by the Archaeology Branch, Ministry of Forests, Lands, Natural Resources and Rural Development.

First Nation Cultural Heritage Management

Many BC First Nations maintain cultural heritage policies and/or heritage permitting systems to assert oversight over Indigenous cultural heritage management and to ensure a high standard of archaeological practice. Contact should be made with locally affected Nations prior to any heritage study or project work with the potential to encounter cultural heritage materials to ensure adherence to Nation-preferred heritage protections, permits, and policy.

Potential to Encounter Archaeological Sites

Any project involving ground alterations has the potential to expose undocumented archaeological sites. Common forms of ground disturbances that have led to site discoveries include land grading, vegetation clearing/grubbing, excavation, asphalt/concrete removal, geotechnical drilling, access road or trail building, foundation demolition, heavy equipment movement, habitat planting, stream and pond channeling or dredging.

Other kinds of work activities where teams may encounter undocumented archaeological sites include field teams working in proximity to natural, undeveloped or minimally disturbed terrain. Teams involved in field surveys, field inspections, or inventories of natural ground and waterways, riparian areas, municipal parks and trails, forested areas, cut bank or erosion area, and so on may encounter exposed archaeological materials.

City workers or contractors engaged in any activity that may result in archaeological materials identification should be made aware of HCA site protection legislation and field supervisors properly versed CFP procedures.

Types of Archaeological Sites

The following site types are well-known across the lower Fraser River region and may be encountered in the City of Coquitlam. The following site types may contain a range of artifact types and sediment signatures.

- **Stone tool sites** containing isolated artifacts or accumulations of stone tool working debris.
- **Habitation sites** show accumulations of food remains, tools, and evidence such as hearths indicating short term and seasonal camps and settlements used for travel and resource procurement as well as large and permanent villages.
- **Surface features** such as cultural depressions created by former habitations, earthen fortifications, burial mounds, and rock cairns.
- **Wet sites** contain preserved organic materials like woven basketry or wood tools in addition to other cultural material; these sites form under special preservation conditions typically anaerobic water saturated sediments along waterways and floodplains.
- **Culturally Modified Trees (CMTs)** include bark stripped trees, planks, and territory markers.
- **Rock art** including pictographs (painted rock images) and petroglyphs (images carved or pecked into rockfaces or boulders).

Archaeological Chance Find Procedure

In the event of found or suspected archaeological material, follow the procedures outlined below.

STEP 1: WATCH for potential archaeological materials

- ⇒ Know that undocumented archaeological sites are expected throughout Coquitlam.
- ⇒ Know that archaeological materials are protected by law and must be reported.
- ⇒ If you believe you may have encountered archaeological materials (either intact or disturbed) follow the steps outlined below.

STEP 2: STOP work in proximity to the material

- ⇒ If known or suspected archaeological materials are encountered, STOP work in the immediate vicinity.
- ⇒ Do not disturb, move, relocate, or collect the material.

STEP 3: REPORT observed materials

- ⇒ Alert the site supervisor that suspected archaeological materials have been observed.
- ⇒ The site supervisor will ensure appropriate contact is made with City managers who will in turn reach out to archaeological professionals.

STEP 4: CONTACT archaeological professionals

- ⇒ Seek immediate advice from an archaeological professional.
- ⇒ Teams may be advised to protect the area with flagging or cones until the area can be assessed by the appropriate representative.
- ⇒ Teams may be requested to provide locational details or photographs of the material.

STEP 5: AWAIT advisement

- ⇒ Wait for instructions from the appropriate representative; do not begin ground disturbing work until cleared to do so.
- ⇒ Prepare and submit an incident report to ensure compliance with appropriate regulators and interest groups.

Archaeological Chance Find Procedure - Suspected Ancestral (Human) Remains

In the event of found or suspected human remains, follow the procedures outlined below*.

STEP 1: STOP all activity at the job site immediately, including the removal of backfill. Do not rebury the remains.

STEP 2: REPORT to the City Project Manager. The Project Manager will contact an archaeological professional and determine the appropriate course of action. In most cases, the archaeology professional will visit the site to determine if the materials are reasonably expected to be human and archaeological. If warranted, the consultant will notify the Archaeology Branch and the RCMP, the Office of the Coroner, and affected First Nations. The Coroner will affirm whether the remains are archaeological and not of forensic concern. The archaeologist will inform the Archaeology Branch and First Nations will be consulted to determine culturally appropriate handling protocols and subsequent project management options.

STEP 3: PROTECT the affected location with flagging or cones to prevent additional disturbance and for privacy. Do not photograph the material.

STEP 4: TREAT the remains with dignity and respect. Do not allow bystanders to take photographs or video.

STEP 5: AWAIT advisement.

* If it is reasonable to think the human remains are not archaeological but forensic in nature, an immediate call to the RCMP is required.

Management Options

If determined that an archaeological or cultural heritage site (intact or disturbed) is present, an archaeologist will coordinate communications with the City, local affected First Nations, and the Archaeology Branch to evaluate management options. Archaeology Branch and First Nations approval and additional permitting may be required prior to the implementation of management options.

Examples of potential management options are provided below. Options will vary based on site characteristics, proponent needs, and Archaeology Branch and First Nation requirements.

Option A: Site avoidance through project redesign or relocation. Site avoidance is always preferred. Avoidance minimizes impacts to irreplaceable archaeological sites and reduces cost and schedule impacts.

Option B: Systematic data recovery through controlled archaeological excavation or other method. Data recovery is destructive to archaeological sites and will entail consideration of costs and schedule coordination.

Option C: Monitoring of construction activities by a professional archaeological team. Monitoring is appropriate where project impacts cannot be evaluated before construction (due to impenetrable surfaces or underground facilities, for example) or where potential to encounter archaeological materials is present following impact assessment or systematic data recovery.

Best Practices for CFP Implementation

- A Chance Find Procedure is best applied as an outcome stemming from archaeological assessment – as a last step verification that archaeological materials have not been overlooked in project area assessments, or where there is a professional assessment that documents a low expectation for encountering archaeological materials in a work area.
- A Chance Find Procedure is not an acceptable replacement for a professional archaeological overview (AOA) or archaeological impact assessment (AIA) or a well-designed and implemented archaeological construction monitoring plan for many areas. Engagement with professional archaeological teams, affected First Nations, or the Archaeology Branch will assist in appropriate heritage study approaches.
- Chance Find Procedure training must be delivered by professional archaeologists and local area First Nations who wish to contribute to CFP presentations.
- Chance Find Procedures should be summarized regularly as part of job or project requirements, and CFP training repeated by the archaeological and First Nation team for new employees, project teams, and subcontractors.
- Chance Find Procedures do not supersede any requirements or policies pertaining to cultural heritage management by First Nations with interests in the area. Proponents are encouraged to seek input from interested First Nations on area-specific CFPs as part of any project engagement process.

Contact List

Archaeology Branch

Paula Thorogood	Planning and Assessment Manager	250-953-3300	Paula.Thorogood@gov.bc.ca
Nathan Friesen	Planning and Assessment Supervisor	250-953-3306	Nathan.P.Friesen@gov.bc.ca

City of Coquitlam

Main Reception 604-927-3000

Police and Coroner

RCMP (Non-emergency)	Coquitlam	604-945-1550
BC Coroners Service	Lower Mainland Region	604-660-7708

Area First Nations

Kwikwetlem First Nation 604-540-0680

Katzie First Nation 604-465-8961

Kwantlen Nation 604-888-2488

Musqueam Indian Band 604-263-3261

Stó:lō Nation 604-824-2420

Tsleil Waututh Nation 604-929-3454

Archaeological Site and Materials Identification

The following archaeological sites and artifacts are common to the lower Fraser River region. This guide is to assist in the recognition and protection of archaeological materials found by chance. If you identify any archaeological material, stop work immediately and contact a professional archaeologist.

Artifacts

Artifacts are objects made or modified by humans and may be formed of stone, bone, antler or wood. Bone, antler and wood tools were produced in abundance, but stone artifacts are the most common artifacts found in the lower Fraser region because of the preservation durability of stone. Bone and antler were fashioned into a variety of items, including needles, knives, points, jewelry, awls and scrapers. Wood was used to make implements like spoons and bowls, handles, ceremonial objects, canoes, houses, and much more.



Photo Credit: RBCM, Archaeology Collection. Antler and wood tools (<https://learning.royalbcmuseum.bc.ca>)

Stone tools common to this region include projectile points, knives, adzes (axes), scrapers, mauls (hammers), net weights, beads, and more. Archaeologists distinguish chipped stone from ground stone artifacts, each distinguished by the mode of manufacture, either flaking scars or grinding and polishing marks. Stone flakes or 'debitage' is produced during the process of making stone tools. These flakes were sometimes used as tools themselves or were left behind at the stone tool working site. Culturally produced debitage shows features distinctive from naturally broken rock, gravel or crush, but these signatures can be difficult to identify to an untrained eye. Stone artifacts were produced from dacite, quartzite, slate and nephrite as well as obsidian, chert, and other materials. Stone was acquired locally or transported or traded over long distances; high-quality materials like obsidian has been traced to locations from Prince Rupert to Oregon and beyond.

Artifacts may be found as isolated finds or in association with other cultural materials.

Archaeological Chance Find Procedure



Photo Credit: B&OA, Chipped stone artifacts from Coquitlam Lake.



Photo Credit (left): B&OA, Nephrite ground stone adze from Port Coquitlam. Photo Credit (right): RBCM, Archaeology Collection. Ground stone hand mauls (<https://learning.royalbcmuseum.bc.ca>)

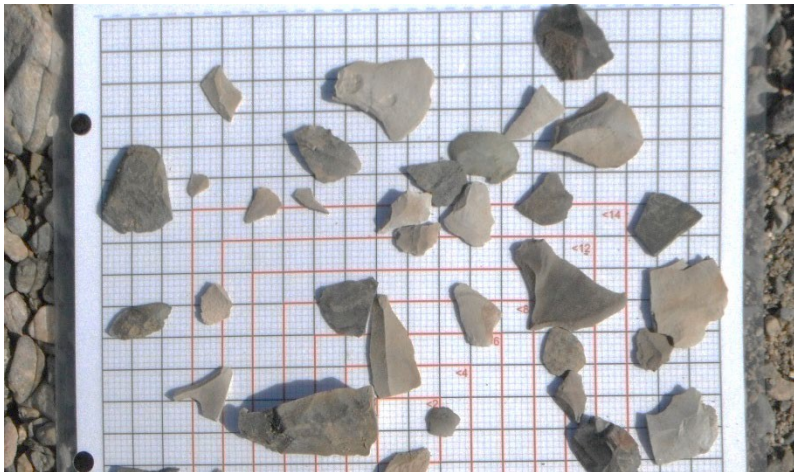

Photo Credit: B&OA, Stone tool debitage from BC Interior.

Beads

Beads were made from a variety of materials including stone, shell, bone and glass (in more recent times). Shell and stone disc beads were used in jewelry, regalia and in mortuary practices across the Northwest Coast. On the Lower Fraser it is most common to find stone beads at archaeological sites fashioned from mud or silt stone, slate, or other softer stone. At some burial sites, individuals of rank were laid to rest with thousands of stone and shell beads.



Photo Credit: B&OA, Ground stone beads from near Agassiz.

Indigenous Historical Artifacts

Indigenous use of European materials in the years following contact are often found in early historic sites. Ceramics, glass, and metal were valued for their strength, durability, ease of access, or aesthetic properties. Glass was worked using traditional stone tool techniques in the same way as obsidian (a natural volcanic glass). Clay pipes were adopted by Indigenous peoples who several centuries earlier had introduced the practice of tobacco smoking to European traders. Glass beads were used by European fur traders to trade with Indigenous peoples; trade beads were initially valued for their vibrant colour and the expectation of beads as a wealth item.

Photo Credit (left): B&OA, Worked glass and clay stone pipe, Coquitlam.



Photo Credit (middle): <https://www.canadashistory.ca/explore/fur-trade/tobacco-pipes>. Photo Credit: Oregon Museum of Natural and Cultural History, Glass trade beads (<https://mnch.uoregon.edu/index.php/collections-galleries>).

Hearths

Hearths are the remnants of fires identifiable by dense black charcoal, ash and heat oxidized sediments. While natural forest fires may also leave traces of burning, hearths tend to be more defined and frequently show concave bases, evidence of repeated use, and contain or are in proximity to burned bone, fire-altered rock, and artifacts.

Fire-Altered Rock

Fire-altered rock (FAR) is rock modified by repeated heating and cooling. Heating small, rounded river cobbles and immersing the hot stones in water filled baskets or boxes was a frequently used cooking technique called 'stone boiling'. Heated stones were also used to warm clothing and bedding. The repeated heating and cooling of FAR created distinctive fracture and colour patterns that are easily distinguished from naturally broken rock. FAR shows irregular breakage patterns, is frequently deeply pitted, is often deep rust or black in colour, and may be found mixed in charcoal and ash laden sediments. As FAR is often found in abundance around settlement areas or near cooking features and hearths, it is a frequent first indicator of the presence of archaeological sites. Often mixed in FAR deposits are boiling stones—small, rounded pebbles that have not yet been fractured by thermal processes



Photo Credit: B&OA, Fire altered rock, Coquitlam.



Shell and Non-Shell Midden

Midden deposits are generally indicative of camp or village sites. Middens accumulate through the repeated, ongoing use of an area where food remnants or the debris of daily living build up in layers at a site over time. In coastal areas, shellfish provided an abundant food source and, middens contain abundant fragmented or whole shell typically embedded in dark, greasy, sediments rich in charcoal, ash, fire cracked rock, burnt materials, and artifacts. Because shell neutralizes the acidity in soil, shell middens enhance preservation of organic food remains and tools, and fish and mammal bone, wood, antler, and botanical remains are often well-preserved in shell midden sites.

Non-shell middens are accumulations of living materials formed at camps and settlements away from marine waterways. Non-shell midden shows layered deposits of dark sediments, ash, and sometimes sand and clay in sediments with little to no shell. These deposits rarely contain bone, antler, or wood remains due to poorer preservation environments.

In Coquitlam, non-shell middens are the more common site type but there are a few examples of inland shell midden sites associated with camps or settlements where shellfish was transported to locations by travel or trade.



Photo Credit (left): B&OA, Non-shell stratified midden Port Coquitlam. Photo Credit (right): Shell midden, Vancouver Island (<https://learning.royalbcmuseum.bc.ca/pathways/can->)

Surface Features

Surface features are non-portable cultural formations visible on the landscape. Features may include pits or depressions, earthen mounds or rock cairns, petroforms (rock arrangements) or trails. Cultural depressions may indicate the location of semi-subterranean winter dwellings, plank houses where midden accumulated around the outside of structures, cache pits used for tool or food storage, or pits and trenches used for food cooking or processing. Cultural depressions are identifiable by their uniform shape (usually round or rectangular), a berm may be present around the edge of features, the presence of associated artifacts, or concentrations of charcoal, ash, and fire altered rock.

Cultural mounds or rock cairns are other familiar surface features. Earthen burial mounds and rock cairns are part of a mortuary tradition found throughout the lower Fraser region over the past 1,500 years. Cultural mounds and cairns range in size from around a meter in diameter to more than 12 meters across. Individual occurrences or clusters of well-formed oval or circular mounds of earth and rock should trigger archaeological assessment.



Photo Credit: SFU Museum, Winter pit house village, Lillooet.

Rock Shelters and Caves

Rock shelters were used, among other purposes, as camps, spiritual or burial locations, and storage caches. Shelters can be found associated with overhangs of large boulders, indentations in rock bluffs or in caves. Shelters often associate with artifacts, rock art, and hearth features.

Ancestral (Human) Remains

Human remains are especially sensitive and significant finds. Any potential human bone requires immediate implementation of the CFP. Ancestral remains are frequently present at archaeological locations and may be found articulated in a burial context or as scattered fragments.

Petroglyphs and Pictographs (Rock Art)

Northwest Coast rock art includes images depicted on boulders, rock overhangs, rock faces, or other exposed rock surfaces. Pictographs are drawings or designs painted on rock using pigments like ochre or charcoal mixed with grease. Petroglyphs are images incised or pecked into stone. Designs vary widely and often depict animals, humans, or an extensive variety of geometric shapes.



Photo Credit: B&OA, Portion of petroglyph panel at Petroglyph Provincial Park, Nanaimo.



Photo Credit: B&OA, Portion of pictograph panel at Pitt Lake.

Fish Weirs and Traps

Fish weirs are structures constructed to funnel and trap fish for harvesting. Traps were built in intertidal areas along marine and river shorelines and near stream mouths. Weirs vary in form and structure depending on water and shoreline conditions, fish species targeted for harvest, intended volume of harvest, and community preferences. Fish weir sites are identifiable by linear or patterned arrangements of wooden stakes protruding from beach or bank edges or boulder alignments along waterways.



Photo Credit: Washington State Archives, Yelm Jim Fish Trap 1885
<http://www.digitalarchives.wa.gov/Record/View/DAA73FC7A57E989D65B6DBEA419FC89E>

Wet Sites

Wet sites are special preservation environments that form in low oxygen water saturated environments along waterways, in bogs and on floodplains. These locations permit enhanced preservation of organic artifacts like wood, bark, and botanicals. Artifacts found in wet sites have included basketry, twine and rope, wooden tools and weapons, architectural structures, and ceremonial implements made of wood and bone.



Photo Credit (left): Mike Blake. Ground slate knife with wooden handle, Agassiz. Photo Credit (right): Katherine Bernick, Waterlogged and preserved basket, Coquitlam.

Culturally Modified Trees (CMTs)

Culturally Modified Trees are trees that have been utilized by Indigenous Peoples for a broad range of cultural uses. Wood was used to build houses, canoes, tools, and weapons. Branches, boughs, and leaves were used to fashion tools, for medicine and in cultural ceremony. Harvesting cedar bark and roots was undertaken regularly to make clothing, cordage, basketry, and sleeping mats, ceremonial regalia, and much more.

Triangular bark stripped cedars are the most common form of CMT; a long, linear triangular bark scar will show where bark was removed from the trunk of a living tree. The exposed scar will heal over time creating a seam on the outer tree bark. This form of sustainable harvesting allowed the same tree to be used multiple times for bark harvesting. CMTs can also show evidence of wood removal where wedges were used to pry rectangular planks of wood from standing, living trees.

Logging and clearing throughout much of Coquitlam municipality reduces the chance that archaeological CMTs remain in most forested areas today, but more recent CMTs where bark or wood was harvested from second-growth forest by Kwikwetlem for cultural uses may be present.



Photo Credit: B&OA, Bark stripped cedars, Coquitlam.

Additional Resources

Learning Portal, Royal BC Museum - <https://learning.royalbcmuseum.bc.ca>

SFU Museum of Archaeology & Ethnology - <https://www.sfu.ca/archaeology/museum.html>

References Cited

Archaeology Branch (1999). Found Human Remains. On file with the Archaeology Branch, Victoria, BC. From http://www.tca.gov.bc.ca/archaeology/policies/found_human_remains.htm

Archaeology Branch (2010). Heritage Conservation Act (RSBC 1996). On file with the Ministry of Tourism, Culture, and the Arts, Victoria, BC. From

***Appendix C -
Additional Information***

AMX-SP

SEMI-PERMANENT WILDLIFE FENCING

15 YEAR PROJECT DURATION
50+ YEAR EXPECTED LIFESPAN

The only purpose-built wildlife fencing products for reptiles, amphibians and small mammals.

Animex Fencing is specifically designed to control animal movement and exclude wildlife from unwanted areas such as roads and construction sites.

The unique features of our environmentally friendly fencing range have enabled contractors, engineers, project managers, farmers and biologists to implement effective wildlife control measures on extensive projects.

All our fencing products and installation guides adhere to environmental regulatory policy across the USA.

We are committed to reducing wildlife mortality and the restoration of fragmented wildlife habitats.



AMX-SP24 Attached to existing fencing

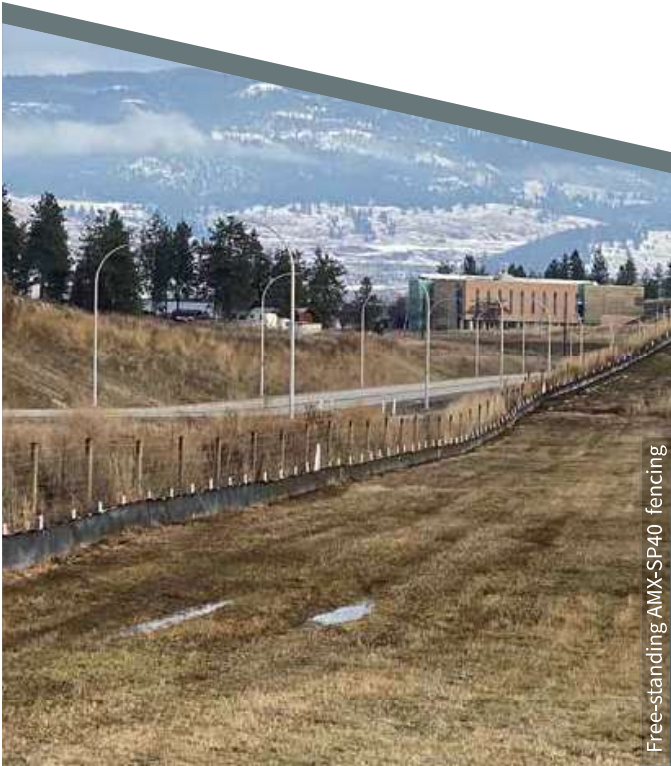

Free-standing AMX-SP40 fencing

SPECIES SUITABILITY

- ✓ SALAMANDERS
- ✓ TURTLES
- ✓ SNAKES
- ✓ FROGS
- ✓ LIZARDS
- ✓ SMALL MAMMALS

242 Main Street, #292
Beacon, NY 12508

(406) 371-2770

info@animexfencing.com

201 - 1065 Canadian Place
Mississauga, ON L4W 0C2

(855) 968-8387

PATENTED DESIGN

ANIMEX AMX-SP FENCE FEATURES

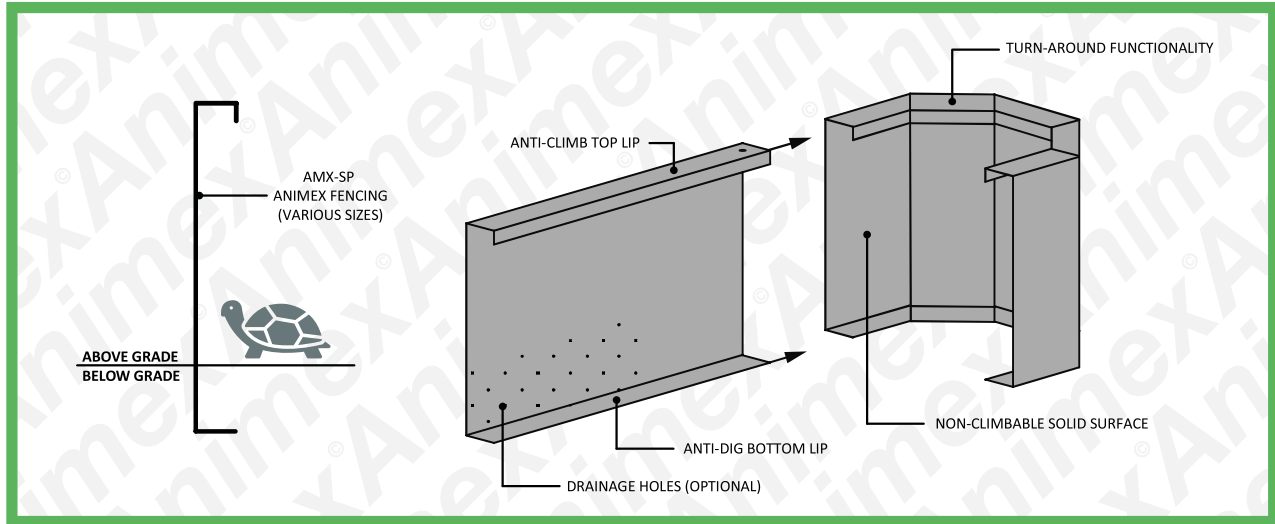

- Anti-Climb & Anti-Dig
- Snowload Durability
- Patented Design
- Drainage Holes (Optional)
- Easily Installed
- Turn-around Functionality
- Shelter Compatible
- One-way Functionality
- UV / Corrosion Resistant
- No Mesh (Animal Safe)

SPECIFICATIONS

Height*: 24in-60in
 Length**: 8ft - 100ft
 Thickness: 0.08in (1/16) / 2mm
 Color: Black

INSTALLATION METHODS

- Free-standing
- Attached to fences
- Attached to barriers

AVAILABLE HEIGHTS*

- ✓ AMX-24
- ✓ AMX-30
- ✓ AMX-40
- ✓ AMX-48
- ✓ AMX-60
- ✓ CUSTOM

* Based on our standard fencing (inches) before installation. We can make custom products to suit any need.

**Available in rolls and sheets

MATERIAL PROPERTIES

TEST	CONDITION	UNITS	VALUE
Density	ASTM-R1505	g/cm3	0.960
Tensile Yield Strength	ASTM-D638	psi	4500
Tensile Impact Strength	ASTM-D1822	ft.lb/in2	90
Vicat Softening Point	ASTM-D1525	°C	128
Low Temperature Brittleness	ASTM-746	°C	<(-75)
Hardness	ASTM-D785	Rockwell R	66
Flammability Rating	UL94 HB	-	Pass
Flow Rate (Perforated only)	ASTM- D4491	gal/sqft/min	15



Animex AMX-SP fencing stops plastic milk bottles from going to landfill. In fact, 365,000 milk bottles are saved per mile of fencing we make! Get in touch to find out more...

242 Main Street, #292
 Beacon, NY 12508

(406) 371-2770

201 - 1065 Canadian Place
 Mississauga, ON L4W 0C2

(855) 968-8387

PATENTED DESIGN

Animex
 WILDLIFE FENCING & CONNECTIVITY

info@animexfencing.com
 Animexfencing.com

Appendix D - Construction Mitigation Plan

Construction Mitigation Plan (CMP)

(To be read with MMCD Platinum 2009 Edition Specifications and Contract's Supplementary Specifications, Section 01 57 01)

This CMP and the Environmental Notes found in cover page of Contract Drawings outlines the minimum mandatory measures that the Contractor must follow during construction.

Work Site Location: Burdett Creek

Burdett Creek has a classification as a red coded watercourse inhabited by Salmonids and/or rare or endangered species year-round.

Construction activities will occur in isolation of any watercourse flow. Bypass must be installed as appropriate following DFO/FLNRO guidelines for proper flow control prior to start of any construction.

I. Scheduling & Environmental Monitoring

- Proposed work will be scheduled for completion within the regional instream work window of July 15, 2026 to October 31, 2026, unless otherwise authorized by the QEP.
- Fish salvage (if needed) will be undertaken as required from areas proposed for flow isolation to be done by an Environmental Monitor (EM) designated by the City.
- An environmental monitor (EM) independent of the construction contractor will be designated by the City to act as EM for the project.
- The EM will provide monitoring of environmentally sensitive construction works to ensure works proceed as per DFO requirements.
- The EM will also monitor the implementation and effectiveness of erosion and sediment control (ESC) measures deployed by the contractor.
- All work which involves heavy machinery that is disturbing earth material must be suspended during substantial rainfall (substantial rainfall will be determined by the EM after a review of weather conditions and existing ground saturation).
- If the proposed works are not conducted in a manner compliant with this CMP or the environmental regulatory approvals, then the EM is required to inform the Contact Administrator (CA), Engineering Inspector, and the contractor of concerns relating to this CMP. The contractor will immediately address deficiencies so that works are compliant with the intent of the CMP.
- The Contractor shall keep on site at all times a copy of this CMP and any environmental approvals required by the Ministry.

II. Riparian Zone

- Any planting requirements will be determined by the EM on site.
- Disturbed areas are to be revegetated with the prescribed grass seed mix and then covered with mulch or straw to prevent erosion and to help seeds germinate.
- All efforts will be made to leave undisturbed native vegetation where possible. Stream banks and ditches are to be restored to their original or better condition if any disturbance occurs.
- The Contractor shall restore all disturbed areas to their original condition or better after construction is completed.

- **Planting Zone**

Seeding :

Broadcast seed to all exposed soil in the riparian zone with coastal reclamation mixture at 75kg/ha or approved equivalent by EM.

III. **Erosion and Sediment Control (ESC) measures**

- Effective erosion and sediment control measures shall be installed by the Contractor prior to any commencement of work.
- These measures are to be inspected by the EM regularly during the course of construction. Necessary repairs/corrections will be made by the Contractor immediately if ESC is compromised or becomes ineffective or as determined by the EM.
- Any debris removed from the work site are to be stabilized to prevent them from entering the watercourse (i.e. covering spoil piles with secured tarps, covering exposed soils with straw, etc.).
- For ESC to be effective on this site the Contractor will follow conditions of this CMP and important ESC measures that will meet or exceed the standards outlined in the DFO "Land Development Guidelines for the protection of Aquatic Habitat" and/or directives provided by agency approvals.
- All works will be conducted by the Contractor in a manner that will prevent the release of sediment or sediment laden waters to storm sewers and swales draining to fish habitat.
- Construction and excavation wastes, overburden, soil or any substance deleterious to aquatic life will be disposed of or placed in a manner that will prevent their entry in to any storm sewer system. All rock or other material will be free of fine sediment and contaminants
- All disturbed slopes and ground surfaces that may contribute sediment-laden water during precipitation events must be stabilized through application of organic (i.e. straw) or inorganic (i.e. plastic) mulches over the course of the project.
- Work will be pursued to completion as quickly as possible once started.
- Prior to commencement of the works the contractor must obtain sufficient quantities of silt fence, straw bales, grass seed mix, sandbags, erosion control blanketing, mulch etc. necessary to stabilize disturbed ground. These materials must be onsite, available for inspection and installation prior to the commencement of any ground disturbance.

IV. **Operation of Machinery**

- Machinery is to arrive on site in good working condition, power washed and free of leaks, excess oil and grease. No fuels, lubricants or any deleterious substance will be permitted to any watercourse at any given time.
- No machine refueling within 30m of any watercourse will be allowed.

V. **Spills**

- A spill containment kit must be readily accessible to each construction equipment on site in the event of release of a deleterious substance to the environment. Any spill of a deleterious substance that enters the watercourse will be immediately reported to the Provincial Emergency Program 24hour phone line at 1-800-663-3456.
- The spill kit must be onsite ready for inspection at commencement of construction. Construction will not be allowed to commence if proper spill kit is not available on site.